



INSTALLATION MANUAL

DCX525

All Digital High-Definition Set-top

©ARRIS Enterprises, Inc. 2015 All rights reserved. No part of this publication may be reproduced in any form or by any means or used to make any derivative work (such as translation, transformation, or adaptation) without written permission from ARRIS Enterprises, Inc. ("ARRIS"). ARRIS reserves the right to revise this publication and to make changes in content from time to time without obligation on the part of ARRIS to provide notification of such revision or change. ARRIS and the ARRIS logo are all trademarks of ARRIS Enterprises, Inc. MoCA is a registered trademark of Multimedia over Coax Alliance. HDMI is a trademark of HDMI Licensing LLC. Manufactured under license from Dolby Laboratories. Dolby, Pro Logic, and the double-D symbol are trademarks of Dolby Laboratories. This product incorporates copy protection technology that is protected by U.S. patents and other intellectual property rights. Use of this copy protection technology must be authorized by Rovi Corporation, and is intended for home and other limited viewing uses only unless otherwise authorized by Rovi Corporation. Reverse engineering or disassembly is prohibited. Other trademarks and trade names may be used in this document to refer to either the entities claiming the marks and the names of their products. ARRIS disclaims proprietary interest in the marks and names of others.

ARRIS provides this guide without warranty of any kind, implied or expressed, including, but not limited to, the implied warranties of merchantability and fitness for a particular purpose. ARRIS may make improvements or changes in the product(s) described in this manual at any time.

The capabilities, system requirements and/or compatibility with third-party products described herein are subject to change without notice.



Safety and Regulatory Information

IMPORTANT SAFETY INSTRUCTIONS

- Read these instructions.
- Keep these instructions.
- Heed all warnings.
- Follow all instructions.
- Do not use this apparatus near water.
- Clean only with dry cloth.
- Do not block any ventilation openings. Install in accordance with the manufacturer's instructions.
- Do not install near any heat sources such as radiators, heat registers, stoves, or other apparatus (including amplifiers) that produce heat.
- Do not defeat the safety purpose of the polarized or grounding type plug. A polarized plug has two blades with one wider than the other. A grounding type plug has two blades and a third grounding prong. The wide blade or the third prong is provided for your safety. If the provided plug does not fit into your outlet, consult an electrician for replacement of the obsolete outlet.
- Protect the power cord from being walked on or pinched particularly at plugs, convenience receptacles, and the point where they exit from the apparatus.
- Only use attachments/accessories specified by the manufacturer.
- Unplug this apparatus during lightning storms or when unused for long periods of time.
- Refer all servicing to qualified service personnel. Servicing is required when the apparatus has been damaged in any way, such as the power supply cord or plug is damaged, liquid has been spilled or objects have fallen into the apparatus, the apparatus has been exposed to rain or moisture, does not operate normally, or has been dropped.

Important Safety Considerations

The mains plug is the main disconnect device. It shall remain readily accessible and operable.

The apparatus shall not be exposed to dripping or splashing and no object filled with liquids, such as vases, shall be placed on the apparatus.

During Transportation to the Subscriber Home

Transport the cable terminal in its shipping box or an equally padded container.

Do not expose the terminal to rain or moisture.

During Installation

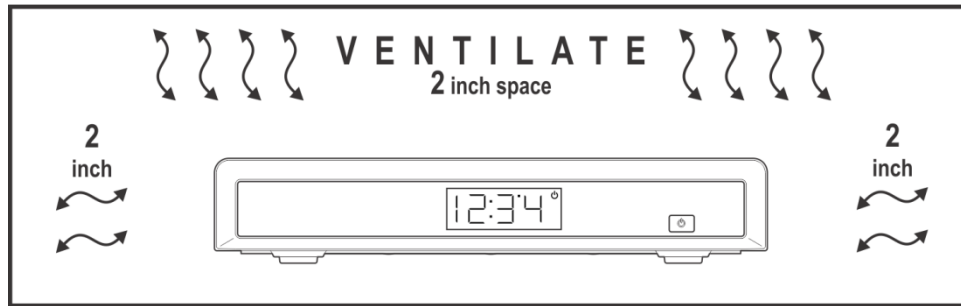

- Do not place the cable terminal in an enclosed area where the cooling vents are blocked or impede the flow of air through the ventilation openings.
- Install the terminal so that its position does not interfere with its proper ventilation. For example, do not place the terminal on a bed, sofa, rug, or similar surface that could block the ventilation openings.
- Install the terminal away from heat sources such as radiators, heat registers, and stoves. Installation of the terminal near consumer electronics devices, such as stereo receiver/amplifiers and televisions, is permitted as long as the air surrounding the terminal does not exceed 40° C (104° F).
- Place the terminal on a flat surface not prone to vibration or impact.
- Do not install the terminal in an area where condensation occurs.
- To prevent the temporary loss of guide data and cause a temporarily non-responding terminal, do not plug the AC power cord into a switched power outlet.

FCC Compliance

Note: This equipment has been tested and found to comply with the limits for a Class B digital device, pursuant to part 15 of the FCC Rules. These limits are designed to provide reasonable protection against harmful interference in a residential installation. This equipment generates, uses, and can radiate radio frequency energy and, if not installed and used in accordance with the instructions, may cause harmful interference to radio communications. However, there is no guarantee that interference will not occur in a particular installation. If this equipment does cause harmful interference to radio or television reception, which can be determined by turning the equipment off and on, the user is encouraged to try to correct the interference by one or more of the following measures:

- Reorient or relocate the receiving antenna.
- Increase the separation between the equipment and receiver.
- Connect the equipment into an outlet on a circuit different from that to which the receiver is connected.
- Consult the dealer or an experienced radio/TV technician for help.

Caution: *Changes or modifications not expressly approved by ARRIS for compliance could void the user's authority to operate the equipment.*

This device complies with part 15 of the FCC Rules. Operation is subject to the following two conditions: (1) This device may not cause harmful interference, and (2) this device must accept any interference received, including interference that may cause undesired operation.

FCC Declaration of Conformity

ARRIS Enterprises, Inc. 3871 Lakefield Drive, Suwanee, GA 30024, 1-215-323-1000, declares that the DCX525 receiver complies with 47 CFR Parts 2 and 15 of the FCC rules as a Class B digital device.

Industry Canada (IC)

This Class B digital device complies with Canadian ICES-003.

Cet appareil numérique de la classe B est conforme à la norme NMB-003 du Canada.

Special Symbols That Might Appear on the Equipment



The exclamation point, within an equilateral triangle, is intended to alert the user to the presence of important installation, servicing, and operating instructions in the documents accompanying the equipment.



This symbol indicates that dangerous voltage levels are present within the equipment. These voltages are not insulated and may be of sufficient strength to cause serious bodily injury when touched. The symbol may also appear on schematics.

Caring for the Environment by Recycling

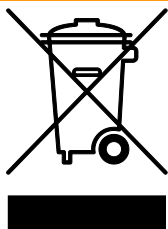

When you see this symbol on an ARRIS product, do not dispose of the product with residential or commercial waste.

Recycling your ARRIS Equipment

Please do not dispose of this product with your residential or commercial waste. Some countries or regions, such as the European Union, have set up systems to collect and recycle electrical and electronic waste items. Contact your local authorities for information about practices established for your region.

Contents

Safety and Regulatory Information	i
Tables	v
Figures.....	vi
Introduction	1
Features	2
Tuners	2
Standard Audio/Video Features.....	2
Standard Data Features.....	2
Standard Miscellaneous Features	2
Getting Help	2
Overview	4
Rear Panel.....	4
Installation.....	5
Before You Begin	5
Cold Reset Procedure	5
Cold Reset Method	6
Video Connection Options.....	7
Audio Connection Options	8
Installation Overview.....	9
CableIn Connection.....	9
Connecting an HDTV — Single Connection for Video/Audio.....	10
HDMI	10
Connecting an SDTV — Single Connection for Video/Audio.....	11
Connecting an SDTV and VCR/DVD Recorder	12
Connecting an A/V Receiver, SDTV and VCR/DVD Recorder	13
Operational Check for the Remote Control.....	15
Configuring the User Settings.....	16
Getting Started	16
Configuring the User Settings Menu Screen	16
Native Mode Settings Screen.....	22
Additional HDMI Settings Screen	25
Additional Closed Caption Settings Screen	27
Subtitle and DVS Settings Screen	29

Advanced Audio/Video Settings Screen	31
Graphics Overlaying the Video	32
Diagnostics.....	33
Using the Diagnostics	33
General Status	34
Purchase Status.....	36
Out-Of-Band (OOB) Status.....	37
Agile OOB Tuner Hunting.....	39
DOCSIS Set-top Gateway.....	40
In-Band Status.....	43
Unit Address.....	45
Current Channel Status	47
RF Modem (Upstream.....	50
Code Modules.....	52
Memory Configuration.....	54
Audio/Video Status	55
Interface Status.....	59
User Setting Status	61
DOCSIS Status.....	62
Application Specific Information.....	65
Interactive Status.....	66
Connected Home	68
Troubleshooting.....	70

Tables

Table 1: Video Output Options.....	7
Table 2: Audio Output Options.....	8
Table 3: User Settings Menu Field Descriptions.....	19
Table 4: Native Mode Settings Field Definitions	23
Table 5: Additional HDMI Settings Field Definitions.....	25
Table 6: Additional Closed Caption Settings Field Definitions.....	28
Table 7: Subtitle and DVS Settings Field Definitions.....	30
Table 8: Advanced Audio/Video Settings Field Definitions.....	32
Table 9: General Status Diagnostic Field Descriptions.....	35
Table 10: Purchase Status Diagnostic Field Descriptions.....	36

Table 11: OOB Diagnostic Field Descriptions.....	38
Table 12: DSG Diagnostic Field Descriptions.....	40
Table 13: In-Band Status Diagnostic Field Descriptions	43
Table 14: Unit Address Diagnostic Field Descriptions.....	45
Table 15: Current Channel Status Diagnostic Field Descriptions	48
Table 16: RF Upstream Modem Diagnostic Field Descriptions.....	51
Table 17: Code Modules Diagnostic Field Descriptions.....	52
Table 18: Memory Configuration Diagnostic Field Descriptions.....	54
Table 19: Audio/Video Status Diagnostic Field Descriptions	55
Table 20: Interface Status Diagnostic Field Descriptions	59
Table 21: DOCSIS Status Diagnostic Field Descriptions.....	62
Table 22: Application Specific Information Diagnostic Field Descriptions.....	65
Table 23: Interactive Status Diagnostic Field Descriptions	66
Table 24: Connected Home Diagnostic Field Descriptions.....	69

Figures

Figure 1: Front and Rear Views.....	1
Figure 2: Rear Panel	4
Figure 3: Connecting an HDTV — Single Connection for Video/Audio.....	10
Figure 4: Connecting an SDTV — Single Connection for Video/Audio	11
Figure 5: Connecting an SDTV and VCR/DVD Recorder.....	12
Figure 6: Connecting an A/V Receiver, SDTV, and VCR/DVD Recorder	14
Figure 7: User Settings Menu—No HDMI Connection.....	17
Figure 8: Default User Settings Menu When an HDMI Connection is in Place.....	17
Figure 9: User Settings Menu—Available Options Illustrated	18
Figure 10: Native Mode Settings menu screen.....	22
Figure 11: Additional HDMI Settings screen.....	25
Figure 12: Additional Closed Caption Settings menu screen	27
Figure 13: Subtitle and DVS Settings Menu Screen	29
Figure 14: Advanced Audio/Video Settings Menu Screen	31
Figure 15: Diagnostic Main Menu Screen	34
Figure 16: General Status Diagnostic Screen.....	34
Figure 17: Purchase Status Diagnostic Screen	36
Figure 18: OOB Status Diagnostic Screen.....	37
Figure 19: DSG Status Diagnostic Screen.....	40

Figure 20: In-Band Status Diagnostic Screens	43
Figure 21: Unit Address Diagnostic Screen	45
Figure 22: Current Channel Status Diagnostic Screens	47
Figure 23: RF Upstream Modem Diagnostic Screen.....	50
Figure 24: Code Modules Diagnostic Screen.....	52
Figure 25: Memory Configuration Diagnostic Screen.....	54
Figure 26: Audio/Video Status Diagnostic Screen	55
Figure 27: Interface Status Diagnostic Screens	59
Figure 28: User Setting Status Diagnostic Screen.....	61
Figure 29: DOCSIS Status Diagnostic Screens.....	62
Figure 30: Application Specific Information Diagnostic Screen.....	65
Figure 31: Interactive Status Diagnostic Screen	66
Figure 32: Connected Home Diagnostic Screens.....	68

1

Introduction

This manual provides instructions for cable operator personnel to install the ARRIS DCX525 All-Digital High-Definition Cable Set-top. This unit includes a high-end processor, expanded memory, and enhanced graphics to support digital and on-demand broadcast and interactive services. It provides a full complement of interconnection options.

The DCX525 provides advanced capabilities, including:

- Authorization and purchase of on-demand programming
- HDTV output through a High-Definition Multimedia Interface (HDMI™)
- Surround-sound audio
- Ethernet port for future home networking applications
- Adaptability to various software platforms

As with all ARRIS digital cable set-tops, the hardware features are enabled by core operating and third-party application software.



Figure 1: Front and Rear Views

Features

Tuners

- Single 1GHz digital video tuner (QAM 64/256)
- MPEG 2 Main Profile @ High Level (High-Definition)
- MPEG-4 H.264 (AVC) High-Definition decode
- One dedicated tuner for the out-of-band (OOB) control channel

Standard Audio/Video Features

- Embedded MediaCipher™ Conditional Access
- Compatible with ARRIS DCT/DCH legacy software API set
- Dolby® Digital, Dolby® Digital Plus, AAC-LC / HE-AAC, MP3
- High-definition (HDTV) decode of MPEG-2, MPEG-4 AVC (H.264)
- SCTE 55-1 Out-of-band
- Video scaling
- Video-in-Graphics
- Accelerated 2-D and 3-D graphics
- 256 MB Flash, 512 MB DRAM
- Front panel Power/Standby LED
- Remote and on-screen diagnostics
- Switched Digital Video capable
- Rovi®, HDCP, DTCP, and CGMS-A content protection schemes on the respective interfaces

Standard Data Features

- 10/100 Mbps Ethernet Port (RJ 45) on the rear panel
- External Infrared Receiver Input

Standard Miscellaneous Features

- Messaging capabilities
- Digital diagnostics

Getting Help

Help with your product is available online and by phone.

Find technical documentation in the CustomerCare 360 Documentation Center (<http://www.arrisi.com/cc360>).

Get release updates and download software from DigitalCM (digitalcm.arrisi.com).

The ARRIS Training Learning Portal provides self-paced product training and course descriptions of instructor-led training classes at <http://www.arrisi.com/support/training>. In many cases training can be given at your location.

The Technical Assistance Center (TAC) provides assistance 24 hours a day, 7 days a week. To open a case, use one of these contact methods:

- Customers in North America should call the TAC at 888-944-HELP (888-944-4357).
- Customers outside North America should call the TAC at IDD (International Direct Dialing Number) + 1 + 215-323-2345.
- For Spanish language support, call 215-323-2346.
- Contact the TAC by e-mail at Tac.Helpdesk@arrisi.com

2

Overview

Rear Panel

The rear panel contains connectors for video, audio, and RF cabling; data output; and modem and data interface connectors. Some connectors are not enabled and require the support of application software.

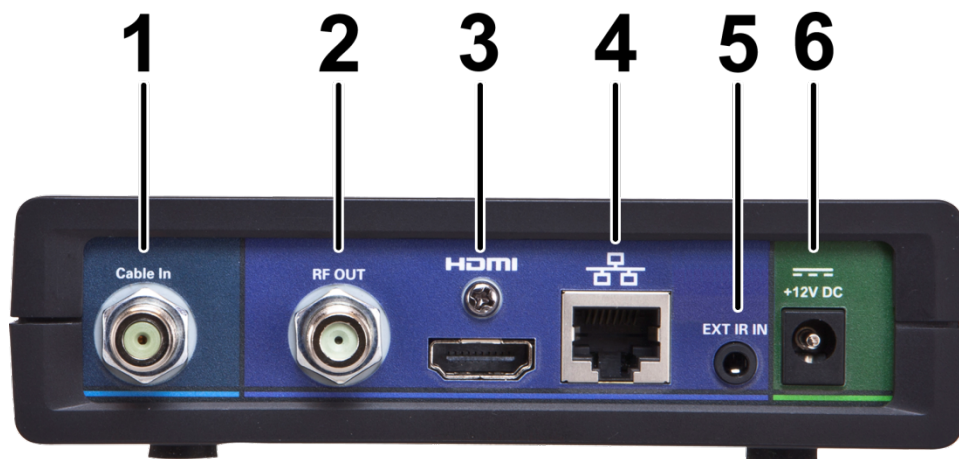

Figure 2: Rear Panel

1	Cable In — Connects to cable signal from the service provider
2	RF Out — Ch 3/4 modulated audio/video (SDTV) to TV or VCR
3	HDMI™ — High-Definition TV (HDTV) connector (Provides Dolby® Digital Plus (7.1) audio, Dolby® Digital 5.1 audio or PCM output, volume controlled)
4	Ethernet* — Network connection
5	Ext IR Input — Connects to a remote control receiver accessory cable
6	Power connector

** Availability of certain features is dependent upon application support.*

3

Installation

Before You Begin

Before you move or change components on the subscriber's entertainment system:

- Review the installation instructions.
- Determine if you are connecting to a standard analog NTSC TV (supporting an RF input), a composite (baseband) video input, or a High-Definition TV (supporting component video input or HDMI™ input).
- Determine if the subscriber has other equipment to be connected to the terminal (home theater or AV receiver, VCR, etc.).
- Verify that you have the necessary cables and other required items.

Cold Reset Procedure

This section describes the Cold Reset procedure for the ARRIS DCX525 set-top. The cold reset is generally used by operational and field personnel to accomplish the following:

- Restore the set-top to a known state.
- Clear channel maps and application settings.
- Remove application and software objects above the platform code.
- Clear the Out of Band (OOB) Last Known Carrier (LKC) and force the units to hunt for a new OOB control channel.

Cold Reset Method

1. Remove the set-top from its packaging.
2. Plug in a serial connector to the DCX525 and open a terminal window.
3. AC power cycle the set-top.
4. Once the front panel indicator is illuminated after power has been applied to the DCX525, quickly press and release the <Select> button on the remote.
If the <Select> key is properly detected, the optional terminal window indicates that the <Select> key was received.
5. Press the following sequence of numbers on the remote control: 3, 2, and 8.
As each number in the sequence is pressed, the terminal window echoes back each button press as D, C, and T for each number in the sequence.
The set-top now cold resets.

Note: The <Select> key is labeled <OK> on some remotes.

Video Connection Options

Use the following guidelines to determine the best video connection for the subscriber's home entertainment system. To determine the available video inputs on the TV, check the manual supplied with the TV or the TV itself.

Table 1: Video Output Options

Connector	TV Type	Description
HDMI™	HDTV and SDTV	HDMI provides the highest-quality digital HD video signals. If the TV has an HDMI or a DVI input, use the HDMI Output. HDMI is a video and audio connection. If you use HDMI, no separate audio connection to the TV is required.
RF OUT (coax)	SDTV	Use the RF OUT (coax) connector for SDTV. The RF OUT (coax) connection is a video and audio connection. If you use the RF OUT, no separate audio connection to the TV is required.

Audio Connection Options

When connecting to a home theater receiver, depending on its inputs, you can use the following DCX525 audio outputs:

Table 2: Audio Output Options

Connector	Description
HDMI	<p>Unlike a DVI connection, an HDMI connection is capable of carrying digital video and audio signals to the TV or a home theater receiver equipped with HDMI switching support.</p> <p>The HDMI connection can deliver Dolby Digital Plus, Dolby Digital, Linear PCM, and other digital audio formats to a compatible TV or home theater receiver.</p>
RF OUT (coax)	<p>If the audio receiver does not support Dolby Digital, use the RF OUT (coax) output to connect to the audio receiver (if the receiver supports RF (coax) in..</p>

The cabling diagrams show audio/video (A/V) connections to an audio receiver, where the receiver functions as an A/V router. When connecting to an audio receiver, reference its installation guide for directions on connecting to baseband and digital audio ports.

The VCR and TV receive their A/V signals from the currently-selected input device on the audio receiver. This is important when the subscriber has another A/V device such as a DVD player, a secondary VCR, a CD player, or other electronic component. ARRIS recommends connecting the TV to the monitor output so on-screen menus for the receiver can be displayed. (Receivers themselves often have interactive on-screen menus.)

Installation Overview

1. Determine if you are connecting to a:

High-Definition TV or monitor	Use the HDMI output. No other video connection supports HDTV.
Standard-Definition TV	Connect the RF OUT connector using a 75 ohm RF coaxial cable.

2. Determine if you are connecting the audio to a home theater receiver or directly to the TV:
 - o For an HDMI video connection, no additional audio connections to the TV are required.
3. Locate the cabling diagram(s) that best match the subscriber's configuration.
4. Connect the audio and video cables in a manner matching that diagram.
5. Connect the cable terminal to the coaxial cable wall outlet.
6. Perform the operational check for the remote control.
7. Optimize the High-Definition settings.

Cable In Connection

The first step for all connection options is to connect an RF coaxial cable to the cable wall outlet and the Cable In connector on the DCX set-top.

Connecting an HDTV — Single Connection for Video/Audio

HDMI

If your TV has an HDMI input, this is for both audio and video if you are using the TV speakers. Connect a Standard HDMI cable to the TV and to the HDMI connector on your DCX set-top.

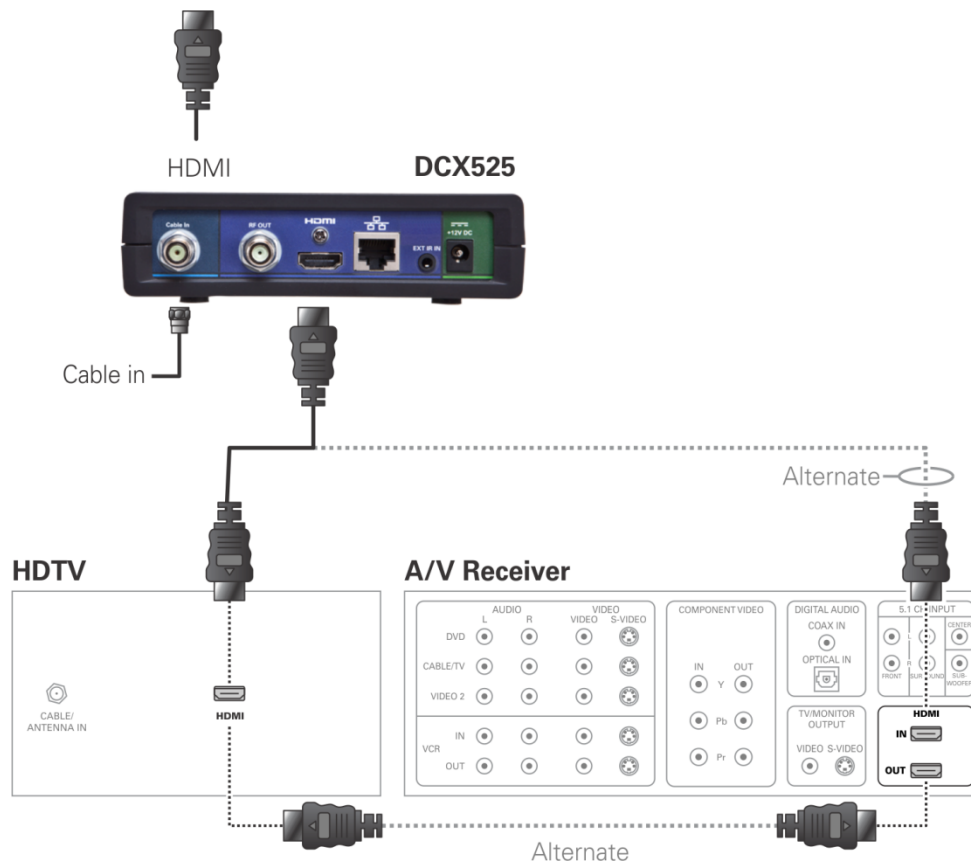

Figure 3: Connecting an HDTV — Single Connection for Video/Audio

Note: Only one HDTV video/audio connection needs to be made to an HDTV.

Note: Solid lines indicate optimum connections.

Note: Optional HDMI connection to AV Receiver shown but not required.

Connecting an SDTV — Single Connection for Video/Audio

1. Connect an RF coax cable to the RF OUT connectors on the DCX set-top and Cable/Antenna IN input connector on the Standard-Definition TV (SDTV).

This video connection method does not support HD video. If you have an HDTV, see [Connecting an HDTV — Single Connection for Video/Audio](#)

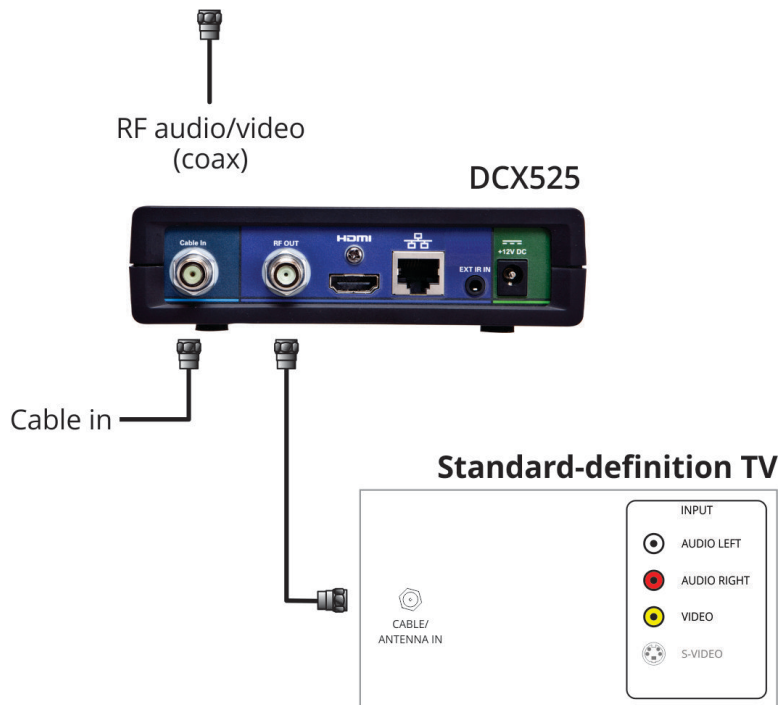

Figure 4: Connecting an SDTV — Single Connection for Video/Audio

Connecting an SDTV and VCR/DVD Recorder

1. Connect an RF (coax) cable to the RF OUT connector on the DCX set-top and the Cable/Antenna IN input connectors on the VCR/DVD recorder.
2. Connect a stereo audio cable to the audio L/R output connectors on the VCR/DVD recorder and the audio L/R input connectors on the Standard-Definition TV (SDTV).
3. Connect a composite video cable to the composite video output connector on the VCR/DVD recorder and the composite video input connector on the Standard-Definition TV (SDTV).

Note: You can also connect the TV to the VCR/DVD using the S-Video connectors (not shown) or RF (coax) cable if supported by your VCR/DVD recorder and SDTV.

These video connection methods do not support HD video. If you have an HDTV, see [Connecting an HDTV — Single Connection for Video/Audio](#).

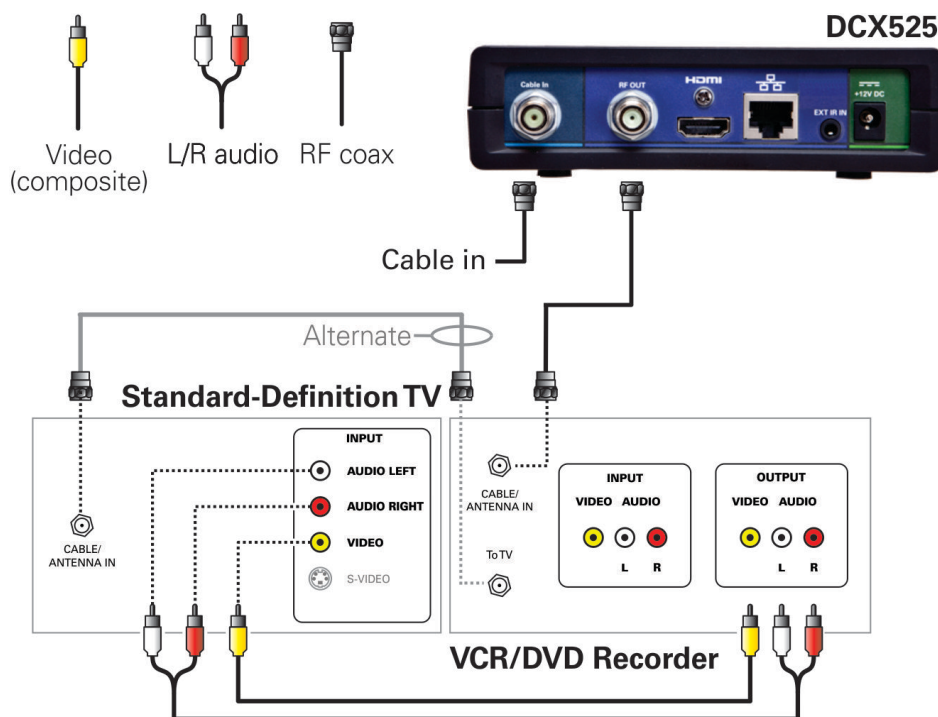

Figure 5: Connecting an SDTV and VCR/DVD Recorder

Connecting an A/V Receiver, SDTV and VCR/DVD Recorder

1. Connect an HDMI cable to the HDMI output connector on the DCX set-top and the HDMI input connector on the A/V receiver.
2. Connect a stereo audio cable to the VCR/DVD recorder audio L/R output connectors on the A/V receiver and the audio L/R input connectors on the VCR/DVD recorder.
3. Connect a stereo audio cable to the audio L/R output connectors on the VCR/DVD recorder and the VCR audio L/R input connectors on the A/V receiver.
4. Connect a composite video cable to the composite video input connector on the VCR/DVD recorder and the composite video VCR output connector on the A/V receiver.
5. Connect a composite video cable to the composite video output connector on the VCR/DVD recorder and the composite video VCR input connector on the A/V receiver.
6. Connect a composite video cable to the composite video input connector on the Standard-Definition TV (SDTV) and the TV/monitor composite video output on the connector on the A/V receiver.

Note: These video connection methods do not support HD video. If you have an HDTV, see [Connecting an HDTV — Single Connection for Video/Audio](#)

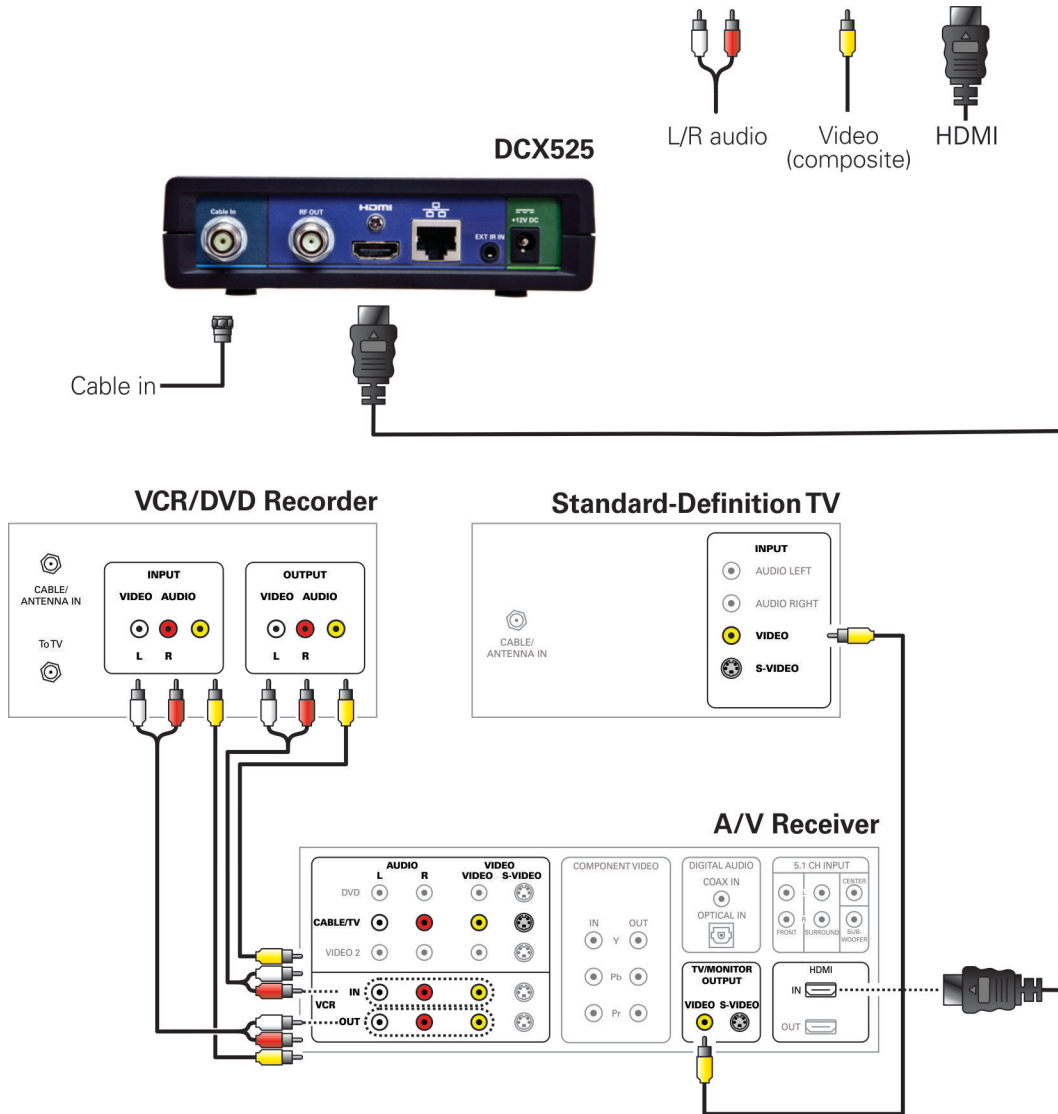

Figure 6: Connecting an A/V Receiver, SDTV, and VCR/DVD Recorder

Operational Check for the Remote Control

The operational check tests communication with the remote control:

Feature	Testing Procedure
Power on	Press power on the remote control to turn on the DCX525.
Channel selection	Scan through the channels by using the channel + or - keys on the remote control Tune to several channels by entering the channel number using the numeric keys.
Volume control	Press volume + or - on the remote control to set the volume to a desired level. Press mute to turn the sound off. Press mute again to restore the sound.

If the DCX525 does not operate properly, refer to the Troubleshooting section.

4

Configuring the User Settings

Getting Started

The following describes how to configure the audio (for HDMI connections), SD and HD video settings, and closed caption settings for the DCX525.

Before you adjust the output settings:

1. Connect the DCX525 to the TV and other home entertainment devices.
2. Plug the DCX525 into an AC power outlet.
3. Initialize the DCX525 and authorize it for services.
4. Turn the TV on.

When using an HDMI connection between the DCX525 and the television, be sure to have the cable connected and the TV powered on before adjusting the video settings. ARRIS recommends certified standard (category 1) HDMI cables for 1080i or 720p resolutions. A certified high speed (category 2) HDMI cable is recommended for resolutions of 1080p.

Configuring the User Settings Menu Screen

To configure the DCX525 settings on the User Settings menu screen, power off the DCX set-top and then press the menu key on the remote control. If your TV is on, the on-screen User Settings menu lists the DCX525 settings that can be adjusted.

```

User Settings
> Tv Type           16:9 (4:3 Letterbox: 4:3 pan scan)
  HDMI Output       1080i (720p, 480p, 480i, native)
  4:3 Override      480i (480p, Stretch, Off)
  Stretched Graphics Disabled

Native Mode Settings >>>
Additional HDMI Settings >>>

Closed Captions    Disabled (Enabled)
Additional Closed Caption Settings >>>

Subtitle and DVS Settings >>>
Advanced A/V Settings >>>

Front Panel Brightness Normal (High, Off, Low)
Restore All Defaults   Menu Version 3.6
```

Figure 7: User Settings Menu—No HDMI Connection

If the DCX525 is connected via HDMI to a display device such as a television, the default User Settings menu is updated to reflect this information as shown in the following example.

```

User Settings
> Tv Type           16:9
  HDMI Output       1080i
  4:3 Override      480i
  Stretched Graphics Disabled

Native Mode Settings >>>
Additional HDMI Settings >>>

Closed Captions    Disabled
Additional Closed Caption Settings >>>

Subtitle and DVS Settings >>>
Advanced A/V Settings >>>

Front Panel Brightness Normal
Restore All Defaults   Menu Version 3.6
```

Figure 8: Default User Settings Menu When an HDMI Connection is in Place

Use your remote control to navigate the on-screen display:

- Press the ▲ and ▼ keys to highlight the setting you wish to change.
- Press the ► key to select an option for that setting.
- To exit the setting and move to another setting, use the ▲ and ▼ keys.
- To exit the menu and save your settings, press the power or menu key.

If the User Settings menu does not display on the HDTV Screen, the TV may not support the default video output settings. Connect the set-top to a Standard-Definition connection in order to view the menu. See the Troubleshooting section for more information.

The User Settings menu options available from the main screen are illustrated and defined below.

```

User Settings
> Tv Type          16:9 (4:3 Letterbox: 4:3 pan scan)
  HDMI Output      1080i (720p, 480p, 480i, native)
  4:3 Override     480i (480p, Stretch, Off)
  Stretched Graphics Disabled

Native Mode Settings >>>
Additional HDMI Settings >>>

Closed Captions  Disabled (Enabled)
Additional Closed Caption Settings >>>

Subtitle and DVS Settings >>>
Advanced A/V Settings >>>

Front Panel Brightness Normal (High, Off, Low)
Restore All Defaults  Menu Version 3.6
```

Figure 9: User Settings Menu—Available Options Illustrated

Table 3: User Settings Menu Field Descriptions

Setting	Description
TV Type	<p>Allows you to specify the style of television connected to the DCX525. The 16:9 option is the default.</p> <ul style="list-style-type: none"> • 16:9 — A widescreen television is connected to the DCX525. • 4:3 Letterbox — A standard-screen television is connected to the DCX525 and widescreen programs should be scaled to fit the screen with black bars above and below the picture. • 4:3 Pan Scan—A standard-screen television is connected to the DCX525 and widescreen programs should be cropped so the picture fills the entire screen.
HDMI Output	<p>Allows you to select the video format of the HDMI output:</p> <ul style="list-style-type: none"> • For ALL programs when the 4:3 Override setting is set to either Off or Stretch. • For ONLY widescreen programs when the 4:3 Override is set to either 480i or 480p. <p>The 1080i option is the default.</p> <ul style="list-style-type: none"> • 1080p60 — High-Definition 1080p60 format (1920 x 1080 pixels with progressive scanning at 60 frames per second). This is only available with HDMI. For component output, 1080p is down-converted to 480i. • 1080i — High-Definition 1080i format (1920 x 1080 pixels with interlaced scanning at 30 frames per second). • 720p — High-Definition 720p format (1280 x 720 pixels with progressive scanning at 60 frames per second). • 480p — Enhanced-Definition 480p format (720 x 480 pixels with progressive scanning at 60 frames per second). • 480i — Standard-Definition 480i format (720 x 480 pixels with interlaced scanning at 30 frames per second). • Native — Format that most closely matches the program's native format according to the list of compatible formats selected from the Native Mode Settings menu screen. <p><i>Note: Not all televisions will support all available video formats. Consult the television's user manual for more information on video format compatibility.</i></p> <p><i>The DCX525 can detect when the HDMI connection is in use. If you are not using the HDMI connection on the DCX525, the Additional HDMI Settings option is disabled and can't be selected in the menu..</i></p> <p><i>Most new HDTVs are equipped with at least one HDMI input and can support the 1080p60 format. The DCX525 is designed to provide excellent video quality when converting any program to the 1080p60 video format. If your television supports 1080p60 video input, it is highly recommended to adjust the HDMI Output setting to the 1080p60 setting.</i></p>

Setting	Description
4:3 Override	<p>Allows you to select the video output format of the DCX525 when it is tuned to a Standard-Definition program or playing back a Standard- Definition program. The 480i option is the default.</p> <ul style="list-style-type: none"> • 480i — Standard-Definition 480i format (720 x 480 pixels). • 480p — Enhanced-Definition 480p format (720 x 480 pixels). • Stretch — Automatically stretch all Standard-Definition programs to a widescreen (16:9) aspect ratio and present the video in the format designated by the HDMI Output setting. Note that the Stretch option is only available when the TV Type setting is 16:9. • Off — Widescreen version of a Standard-Definition program with black bars to the left and the right of the picture (pillarbox) and the video presented in the format designated by the HDMI Output setting. <p><i>Note: Not all televisions support all available video formats. Consult your television's user manual for more information on format compatibility.</i></p> <p><i>If the HDMI Output setting is set to either 480i or Native, the 4:3 Override feature is disabled and can't be selected in the menu. The 4:3 Override feature is available when the HDMI Output setting is 1080i, 720p, or 480p.</i></p>
Native Mode Settings	<p>Allows you to customize the Native Mode feature of the DCX525 by selecting the video formats supported by your television.</p> <p>Selecting the Native Mode Settings option presents a new menu screen with settings specific to Native Mode operation. These settings are discussed in more detail below.</p> <p>The Native Mode Settings option is only available when the HDMI Output setting is set to Native. Otherwise, the Native Mode Settings option is disabled and can't be selected in the menu.</p>
Additional HDMI Settings	<p>Available whenever an HDMI device is connected to the DCX525. Selecting this option presents a new menu screen with settings specific to the HDMI connection. These settings are discussed in more detail later in the manual.</p> <p>If no HDMI device is connected to the DCX525, this option is disabled and can't be selected in the menu.</p>
Closed Captions	<p>Turns closed captions off or on.</p> <p>When this option is set to Disabled, the DCX525 does not render (draw) closed captions on any video output.</p> <p>When this option is set to Enabled, the DCX525 renders (draws) closed captions on all video outputs if closed captions are included in the program.</p> <p>Disabled is the default setting.</p>
Additional Closed Caption Settings	<p>Allows you to customize the style and appearance of closed captions.</p> <p>Selecting this presents a new menu screen with settings specific to closed captions, including font style, color, and size. These settings are discussed in more detail below.</p> <p>The Additional Closed Caption Settings option is only available when the Closed Captions setting is set to Enabled. Otherwise, the Additional Closed Caption Settings option is disabled and can't be selected in the menu.</p>

Setting	Description
Subtitle and DVS Settings	Allows you to customize the operation of the subtitle and descriptive video service features. Selecting the Subtitle and DVS Settings option presents a new menu screen with settings specific to subtitle and descriptive video service operation. These settings are discussed in more detail below.
Advanced A/V Settings	Allows you to customize several advanced audio and video features of the DCX525
Front Panel Brightness	Allows you to adjust the brightness level of the front panel display. High — The brightest level. This setting is most useful when using the DCX525 in very brightly lit rooms. Normal — The default brightness level. Low — The lowest (visible) brightness level. This setting is most useful when using the DCX525 in dim or dark rooms. Off —If the set-top is equipped with a backlit power button, the blue backlighting remains illuminated.
Restore All Defaults	To reset ALL of the DCX525 User Settings to their default values, including options stored on other menu screens, move the cursor to this option and press the ► key.

Native Mode Settings Screen

The Native Mode Settings menu is used to configure the operation of the native mode feature on the DCX525. The DCX525 is capable of receiving and decoding a number of different digital video formats. When operating in native mode, the DCX525 generates a video output format that most closely matches the broadcast video format.

For example, if the DCX525 is configured to operate in native mode, a channel broadcast in the 720p format will be output to the television in the 720p format, while a channel broadcast in the 1080i format will be output to the television in the 1080i format.

When using the native mode feature of the DCX525, please exercise caution when selecting the formats from the checklist. If a format is selected that is not compatible with the television, there may be a loss of video whenever the DCX525 is tuned to a channel which is broadcast in that format.

If the television is connected to the DCX525 using an HDMI cable, the DCX525 will automatically customize the checklist of supported formats as reported to it by the television. If the television is connected to the DCX525 using RF OUT (coax) cable, the checklist will need to be customized manually. Note that at least one of the [1080p - 1080i - 720p - 480p - 480i] formats must be selected from the checklist for the DCX525 to operate properly in native mode.

The Native Mode Settings menu screen is illustrated and defined below.

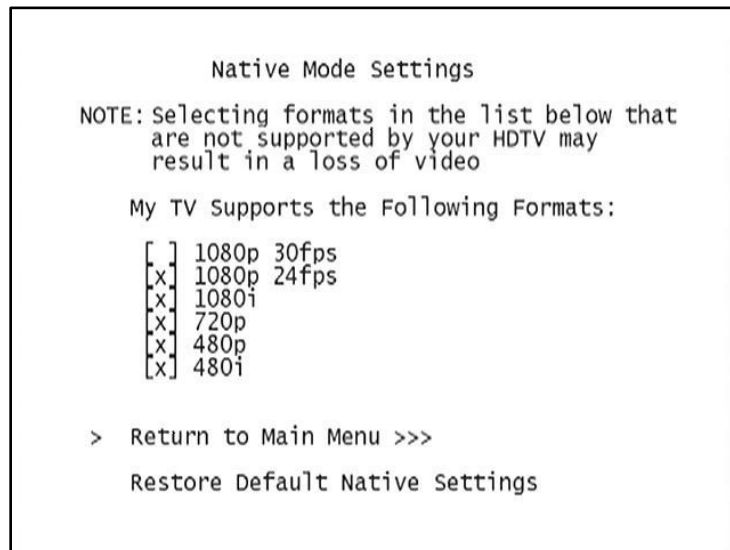

Figure 10: Native Mode Settings menu screen

Table 4: Native Mode Settings Field Definitions

Setting	Description
1080p30 (High Definition)	<p>Generates 1080p30 video on the HDMI output if the program is broadcast in 1080p30 format. The DCX525 cannot convert any other broadcast format to the 1080p30 video format.</p> <p>1080p30 is a high-definition video image with 1920 x 1080 pixels, progressive scanning, and a frame rate of 30 frames per second.</p> <p>This option is only available if the DCX525 is connected to an HDMI display device. If no HDMI connection is detected, this option is disabled and can't be selected in the menu.</p> <p><i>Note: The RF OUT (Coax) output delivers 480i video whenever the HDMI output is delivering 1080p30 video.</i></p>
1080p24 (High Definition)	<p>Generates 1080p24 video on the HDMI output if the program is broadcast in 1080p24 format. The DCX525 cannot convert any other broadcast format to the 1080p24 video format.</p> <p>1080p24 is a high-definition video image with 1920 x 1080 pixels, progressive scanning, and a frame rate of 24 frames per second.</p> <p>This option is only available if the DCX525 is connected to an HDMI display device. If no HDMI connection is detected, this option is disabled and can't be selected in the menu.</p> <p><i>Note: The RF OUT (coax) output delivers 480i video whenever the HDMI output is delivering 1080p24 video.</i></p>
1080i (High Definition)	<p>Generates 1080i video on the HDMI output if the program is broadcast in 1080i format. The DCX525 can also convert any other broadcast format to the 1080i video format.</p> <p>1080i is a high-definition video image with 1920 x 1080 pixels, interlaced scanning, and a frame rate of 30 frames per second.</p>
720p (High Definition)	<p>Generates 720p video on the HDMI output if the program is broadcast in 720p format. The DCX525 can also convert any other broadcast format to the 720p video format.</p> <p>720p is a high-definition video image with 1280 x 720 pixels, progressive scanning, and a frame rate of 60 frames per second.</p>
480p (Enhanced Definition)	<p>Generates 480p video on both the HDMI and RF OUT (coax) outputs if the program is broadcast in 480p format. The DCX525 can also convert any other broadcast format to the 480p video format.</p> <p>480p is an enhanced-definition video image with 720 x 480 pixels, progressive scanning, and a frame rate of 60 frames per second.</p>
480i (Standard Definition)	<p>If this option is selected, the DCX525 generates 480i video on both the HDMI and RF OUT (coax) outputs if the program is broadcast in 480i format. The DCX525 can also convert any other broadcast format to the 480i video format.</p> <p>480i is a standard-definition video image with 720 x 480 pixels, interlaced scanning, and a frame rate of 30 frames per second.</p>

Setting	Description
Restore Default Native Settings	<p>Selecting this option will restore the checklist of video formats to its default configuration. Use this option if audio and/or video has been lost after adjusting these settings from their default values.</p> <p>If you are using the HDMI connection to your television, the checklist will be automatically customized according to the supported formats reported by the television.</p> <p>If you are using the RF OUT (coax) connection to your television, the checklist will have only the 1080i and 480i formats selected.</p>
Return to Main Menu	Selecting this option will return you to the User Settings Menu main screen.

Additional HDMI Settings Screen

The Additional HDMI Settings menu is used to configure advanced options that affect the operation of the DCX525 with other HDMI display devices. Adjustable options include display mode, color space, audio output mode and audio lip sync delay.

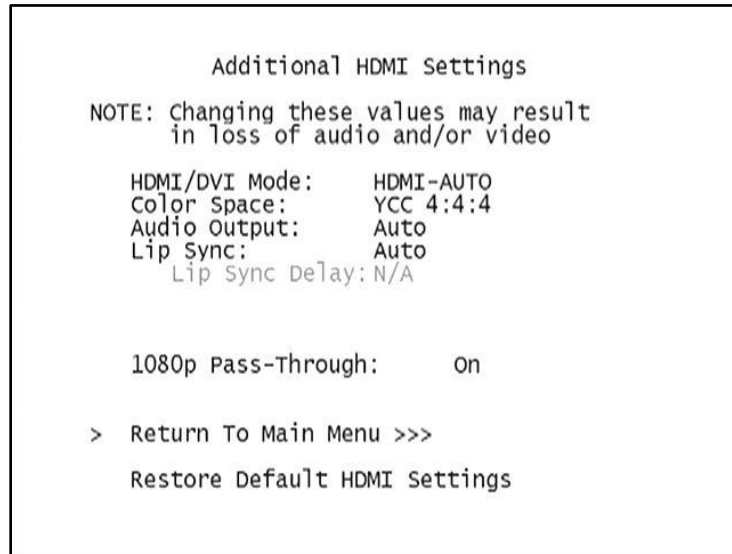

Figure 11: Additional HDMI Settings screen

Table 5: Additional HDMI Settings Field Definitions

Setting	Description
HDMI/DVI Mode	<p>Allows you to optimize the HDMI output to work with both DVI-equipped televisions and HDMI-equipped televisions. HDMI is the default setting.</p> <ul style="list-style-type: none"> • HDMI — Optimized to work with an HDMI television or home theater receiver. • DVI — Optimized to work with a DVI television or display device (connected via an HDMI-to-DVI adapter).
Color Space	<p>Allows you to adjust the color space used by the DCX525 to generate the video signals on the HDMI output. YCC 4:4:4 is the default setting.</p> <p>YCC 4:4:4 — Generates video signals within the YCC color space.</p> <p>RGB — Generates video signals within the RGB color space.</p> <p><i>Note: Adjusting these settings could result in a loss of video. Only a professional installer or someone with a good working knowledge of the color spaces supported by the TV should change this setting.</i></p>

Setting	Description
Audio Output	<p>Allows you to specify the digital audio format delivered over the HDMI output by the DCX525. Options include Auto, L-PCM, and Pass Through. Auto option is the default setting.</p> <p>Auto — Provides the digital audio format specified by the connected device (TV or home theater receiver) when that device was first connected to the DCX525.</p> <p>L-PCM — Provides all audio in the Linear Pulse Code Modulation digital audio format. The L-PCM format is widely supported by most HDMI televisions and home theater receivers.</p> <p>Pass Through — Provides the same digital audio format on the HDMI output as is provided with the program being viewed at that time. For example, if the program has a Dolby Digital soundtrack, the DCX525 passes the Dolby Digital audio to the HDMI output. This option is most useful when connecting the DCX525 to a home theater receiver that has HDMI switching capability.</p> <p><i>Note: Adjusting these settings could result in a loss of audio. Only a professional installer or someone with a good working knowledge of the digital audio formats supported by the TV and/or home theater receiver should change this setting</i></p>
Lip Sync	<p>Allows you to adjust the amount of time the audio signal is delayed with respect to the video signal on the HDMI output. Some HDMI televisions and home theater receivers add an extra delay to the video signal during processing which can produce an effect where the audio noticeably “leads” the video.</p> <p>By default, this option is set to Auto. The options are used as follows:</p> <p>Auto — The DCX525 automatically delays the audio signal on the HDMI output by the amount of time requested by the connected HDMI device.</p> <p>Manual — The DCX525 delays the audio signal on the HDMI output by the amount of time selected for the Lip Sync Delay setting.</p> <p>Off — The DCX525 will not delay the audio signal on the HDMI output.</p>
Lip Sync Delay	<p>Available when the Lip Sync option has been set to Manual.</p> <p>The Lip Sync Delay setting can be adjusted between 0 milliseconds and 500 milliseconds in 50 millisecond increments.</p> <p>If the Lip Sync option has been set to either Auto or Off, this option is disabled and can't be selected in the menu.</p> <p>Use this option to adjust the HDMI audio delay if you notice that the video image routinely seems to be “behind” the audio soundtrack when using your HDMI device.</p>
1080p Pass-through	<p>The set-top provides the same 1080p video format for the HDMI output as the video format provided with the program being viewed at that time.</p> <p>For example, if the program has a video format of 1920 x 1080 pixels with progressive scan at 24 or 30 frames per second, the DCX passes the same video format to the HDMI output without performing a format conversion. This option is most useful when connecting the DCX to a television that supports both 1080p24 and 1080p30 in order to force the best quality video signal to the TV with minimal configuration.</p> <p><i>Note: Not all televisions will support all available video formats. Consult the television's user manual for more information on video format compatibility.</i></p>

Setting	Description
Return To Main Menu	Returns you to the User Settings Menu main screen.
Restore Default HDMI Settings	Restores all of the settings on this screen (HDMI/DVI Mode, Color Space, Audio Output, and Lip Sync) to their default values. Use this option if you lose audio and/or video after changing these settings from their default values.

Additional Closed Caption Settings Screen

The Additional Closed Caption Settings menu becomes available when Closed Captioning is enabled and is used to adjust the various display options for closed caption legibility. Customizable options include font size, font style, font color, and font opacity. You may also select to view different closed caption services if these are included within the broadcast program.

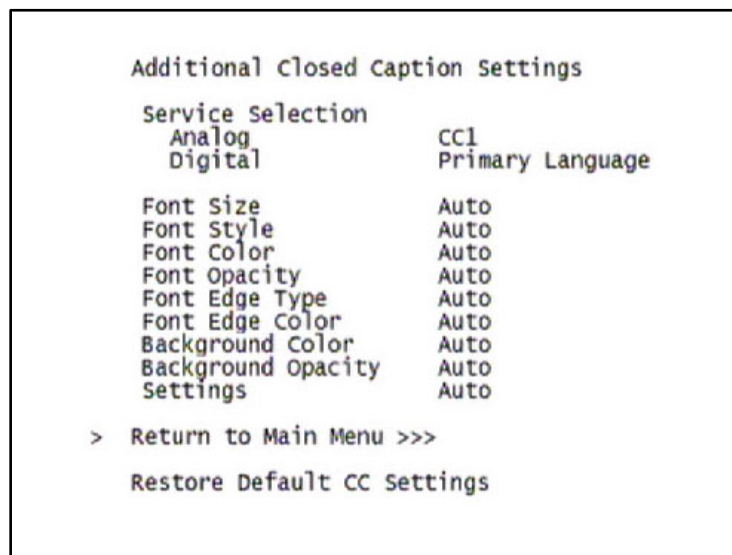

Figure 12: Additional Closed Caption Settings menu screen

Table 6: Additional Closed Caption Settings Field Definitions

Setting	Description
Service Selection	Sets the service used by the DCX525 to render (draw) the closed captions: Analog — Affects closed captions for analog and digital standard definition services. Available options are: CC1, CC2, CC3, CC4, T1, T2, T3, or T4. The default setting is CC1. Digital — Affects closed captions for digital enhanced definition and high definition services. Available options are: Primary Language, Secondary Language, 3, 4, 5, or 6. The default setting is Primary Language.
Font Size	Sets the font size used for rendering (drawing) closed captions. The default setting is Auto. Available options include: Auto, Standard, Large, or Small.
Font Style	Sets the font style used for rendering (drawing) closed captions. The default setting is Auto. Available options include: Auto, Mono Serif, Proportion Serif, Mono No Serif, Proportion No Serif, Casual, Cursive, or Small Capitals.
Font Color	Sets the font color used for rendering (drawing) closed captions. The default setting is Auto. Available options include: Auto, White, Black, Red, Green, Blue, Yellow, Magenta, or Cyan.
Font Opacity	Sets the opacity used for rendering (drawing) closed captions. The default setting is Auto. Available options include: Auto, Transparent, Translucent, Solid, or Flashing.
Font Edge Type	Sets the edge appearance used for rendering (drawing) closed captions. Available options include: Auto, None, Raised, Depressed, Uniform, Left Shadowed, or Right Shadowed. The default setting is Auto.
Font Edge Color	Sets the edge color used for rendering (drawing) closed captions. Available options include: Auto, White, Black, Red, Green, Blue, Yellow, Magenta, or Cyan. The default setting is Auto.
Background Color	Sets the background color used for rendering (drawing) closed captions. The default setting is Auto. Available options include: Auto, White, Black, Red, Green, Blue, Yellow, Magenta, or Cyan.
Background Opacity	Sets the background opacity used for rendering (drawing) closed captions. The default setting is Auto. Available options include: Auto, Transparent, Translucent, Solid, or Flashing.
Settings	Sets the default settings for closed captions (Auto) or restores the settings you had previously configured (User) allowing you to easily change the closed caption settings between their default settings and your customized settings. The default setting is Auto. Available options include: Auto or User.
Return To Main Menu	Returns you to the User Settings Menu main screen.
Restore Default CC	To reset all of the Additional Closed Caption settings to their default values,

Setting	Description
Settings	navigate to this option and press the ► key.

Subtitle and DVS Settings Screen

The Subtitle and DVS Settings menu is used to customize the language and appearance of subtitles and to turn the descriptive video service feature on and off on the DCX525. Subtitles allow a viewer to watch television programs and movies which contain dialogue that is not in the viewer's native language. Subtitles are not included within many television programs (unlike closed captions).

A descriptive video service (DVS) is a special secondary audio track which is included within many television programs and is intended to assist the visually impaired. The DVS audio track provides a verbal description of each scene along with the program's normal dialogue.

The Subtitle and DVS Settings menu screen is illustrated and defined below.



Figure 13: Subtitle and DVS Settings Menu Screen

Table 7: Subtitle and DVS Settings Field Definitions

Setting	Description
Subtitles	<p>The default setting is Off.</p> <p>Off — Subtitles are not rendered (drawn) by the DCX525.</p> <p>On — Subtitles are rendered (drawn) by the DCX525 if they are included in the program and in the language specified by the Language setting.</p> <p>When the Subtitles option is set to On, Language can be selected from the menu.</p>
Language	<p>The Language setting is only available when the Subtitles option is set to On. Otherwise, this setting is disabled and can't be selected in the menu.</p> <p>The default language selection is English.</p> <p>English — Renders (draws) subtitles in English if they are included in the program.</p> <p>Spanish — Renders (draws) subtitles in Spanish if they are included in the program.</p> <p>French — Renders (draws) subtitles in French if they are included in the program.</p> <p>Portuguese — Renders (draws) subtitles in Portuguese if they are included in the program.</p> <p><i>Note: The DCX525 is not capable of translating subtitles from one language to another. For example, if French subtitles are included with the program, the DCX525 cannot translate them to into Portuguese if the Language option has been set to Portuguese. The DCX525 can only display subtitles in the language(s) that have been included within the program.</i></p>
Descriptive Video Service	<p>The default setting is Off.</p> <p>Off — The DVS audio track is not played by the DCX525.</p> <p>On — The DVS audio track is played by the DCX525 if it is included in the program.</p> <p><i>Note: If the DVS setting is disabled and can't be selected from the menu, the software installed on the DCX525 can't support the DVS feature.</i></p>
Return To Main Menu	Returns you to the User Settings Menu main screen.
Restore Default Sub/DVS Settings	To reset all of the Subtitle and DVS settings to their default values, navigate to this option and press the ► key.

Advanced Audio/Video Settings Screen

The Advanced Audio/Video Settings menu is used to customize several advanced audio and video features of the DCX525, most notably the Dolby Volume feature and the Video Sharpness feature.

The Dolby Volume feature provides volume normalization across channels, programs, and commercials. Normalization is a process where the different volume levels across channels, programs, and commercials are adjusted to the same approximate output volume. As a result, sudden volume changes are reduced and the overall volume output of the DCX525 is more consistent.

The Video Sharpness feature is used to soften or sharpen Standard Definition (SD) programs when viewed on the HDMI output. When SD programs are viewed on a large screen television, picture quality can suffer because noise and other imperfections in the picture can be magnified on the large display. The Video Sharpness feature can be used to soften the picture and reduce the appearance of these imperfections.

The Advanced Audio/Video Settings menu screen is illustrated and defined below.

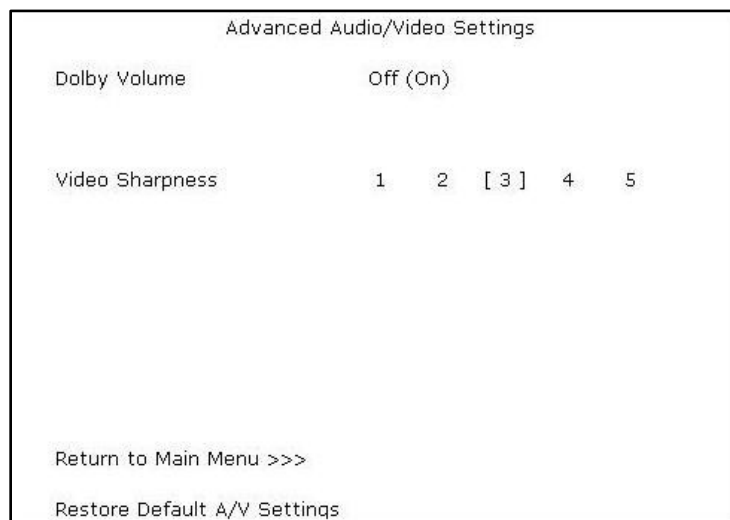

Figure 14: Advanced Audio/Video Settings Menu Screen

Table 8: Advanced Audio/Video Settings Field Definitions

Setting	Description
Dolby Volume	<p>The default setting is Off.</p> <p>Off — Output volume may fluctuate during commercials or when changing channels.</p> <p>On — Maintains a more consistent output volume regardless of the channel or program being viewed.</p>
Video Sharpness	<p>The Video Sharpness setting allows you to adjust the picture sharpness when viewing a standard definition (SD) program on the DCX525.</p> <p>The Video Sharpness setting affects the HDMI output. Level 3 is the default value.</p> <p>The DCX525 supports five distinct levels of analog video picture sharpness. A value of 1 corresponds to a “softer” picture while a value of 5 corresponds to a “sharper” picture.</p> <p>The best sharpness setting depends upon the video connection being used, the display quality of the TV, and your own personal preference.</p>
Return To Main Menu	Returns you to the User Settings Menu main screen.
Restore Default A/V Settings	To reset all of the Advanced Audio/Video settings to their default values, navigate to this option and press the ► key.

Graphics Overlaying the Video

The DCX525 can generate graphics that overlay the video programming or fill the entire television screen. Common examples include on-screen menus (such as the User Setting menu), closed captions, and IPG. The DCX525 overlays these graphics whenever you open a menu, enable closed captions, or scroll through a program grid.

On screen graphics are available for all DCX525 video outputs.

5

Diagnostics

Diagnostics are displayed on the on-screen display (OSD) and front-panel display. They confirm proper installation, including:

- Checking error states and signal integrity
- Identifying the cable terminal on the network
- Verifying communications with the headend

For the diagnostics described in this section:

- All indicators are in decimal notation, unless otherwise noted.
- All signal-level and quality indicators use a 1% to 100% scale, unless otherwise noted.
- All sample displays are illustrative; actual data may differ from the examples.

Using the Diagnostics

To use the diagnostics:

1. Ensure that the DCX525 is installed with the Thin Client software and that it is connected to an AC outlet.
2. Ensure the set-top is powered on.
3. Press power to put the set-top in stand-by mode. Within two (2) seconds, press select on the remote control to enable the diagnostic mode.
4. The Diagnostics main menu is displayed on the OSD.

You can use the following keys on the remote control to navigate the diagnostics menus:

- Press channel ▲, channel ▼, cursor ▲, or cursor ▼ to select d01 through E.
- Press cursor ◀, cursor ▶, select or enter to execute the selected diagnostic.
- Select E from the main menu or press power to exit.

```

                                DIAGNOSTICS
> d01 GENERAL STATUS
d02 PURCHASE/POLL STATUS
d03 OOB STATUS
d04 INBAND STATUS
d05 UNIT ADDRESS/SECURITY
d06 CURRENT CHANNEL STATUS
d07 UPSTREAM STATUS
d08 CODE MODULES
d09 MEMORY CONFIG
d10 AUDIO/VIDEO STATUS
d11 INTERFACE/PORT STATUS
d12 USER SETTING STATUS
d13 DVR/HDD STATUS
d14 DOCSIS STATUS
d15 APPLICATION SPECIFIC INFORMATION
d16 INTERACTIVE STATUS
d17 CONNECTED HOME
d18 KEYPAD/LED
E EXIT

```

Figure 15: Diagnostic Main Menu Screen

General Status

This diagnostic displays system status information on the OSD. The information is updated each time the diagnostic is displayed.

```

                                GENERAL STATUS
ERROR:                          EPO0 CONNECTED DES
PLATFORM ID:                     0x0812
MAPPED PLATFORMID:               0x0812
FAMILY ID:                       0x001D
MODEL ID:                        0xEC04
REMOD CHANNEL:                   03
SETTOP LOCAL TIME:              Nov 04 2010 14:20:15
DST ACTIVE:                      NO
TIME_ZONE:                      GMT-05:00
DST ENTRY TIME:                 Apr 03 2011 07:00:00 GMT
DST EXIT TIME:                 Oct 30 2011 06:00:00 GMT
CURRENT GPS TIME:              Nov 04 2010 19:20:15
COUNTRY CODE:                   USA, 1, UNITED STATES
TOTAL RUN TIME:                 4H 50M
STANDBY TIME %:                 1%
LOW POWER TIME %:               0%

```

Figure 16: General Status Diagnostic Screen

Table 9: General Status Diagnostic Field Descriptions

Field	Description																										
Error	Error codes display on the OSD when an error occurs. If multiple errors occur, the last recorded error is displayed:																										
	<table border="1"> <thead> <tr> <th>Error Code</th> <th>Description</th> </tr> </thead> <tbody> <tr> <td>EP00</td> <td>No error</td> </tr> <tr> <td>EP01</td> <td>Not connected</td> </tr> <tr> <td>EP03</td> <td>DRAM error</td> </tr> <tr> <td>EP04</td> <td>SRAM error</td> </tr> <tr> <td>EP07</td> <td>ROM verification failure</td> </tr> <tr> <td>EP08</td> <td>RAM test failure</td> </tr> <tr> <td>EP09</td> <td>Battery test failure</td> </tr> <tr> <td>EP11</td> <td>Invalid unit address</td> </tr> <tr> <td>EP12</td> <td>Power on self test failure</td> </tr> <tr> <td>EP14</td> <td>GITV startup failure</td> </tr> <tr> <td>EP15</td> <td>TSI structure corrupt</td> </tr> <tr> <td>EP18</td> <td>Driver initialization failure</td> </tr> </tbody> </table>	Error Code	Description	EP00	No error	EP01	Not connected	EP03	DRAM error	EP04	SRAM error	EP07	ROM verification failure	EP08	RAM test failure	EP09	Battery test failure	EP11	Invalid unit address	EP12	Power on self test failure	EP14	GITV startup failure	EP15	TSI structure corrupt	EP18	Driver initialization failure
Error Code	Description																										
EP00	No error																										
EP01	Not connected																										
EP03	DRAM error																										
EP04	SRAM error																										
EP07	ROM verification failure																										
EP08	RAM test failure																										
EP09	Battery test failure																										
EP11	Invalid unit address																										
EP12	Power on self test failure																										
EP14	GITV startup failure																										
EP15	TSI structure corrupt																										
EP18	Driver initialization failure																										
Connected State	A DCX-operations connect or disconnect message determines whether the DCX525 is CONNECTED or DISCONNECTED.																										
Platform ID	A unique 16 bit hexadecimal number that identifies the platform image (also called the ROM ID).																										
Family ID	The manufacturer and product family, in hexadecimal.																										
Model ID	The model, in hexadecimal.																										
Remod Chan	N/A																										
Set-top Local Time	The current time setting on set-top.																										
DST Active	Daylight Saving Time. Yes indicates the DST is active. No indicates the DST is disabled.																										
Time Zone	Time Zone is selected on the set-top.																										
DST Entry Time	The Date and Time the set-top will begin Daylight Savings Time.																										
DST Exit Time	The Date and Time the set-top will end Daylight Savings Time.																										
Current GPS Time	The current OOB time displayed in global positioning system (GPS) seconds from Nov 4, 2010. It is displayed in Greenwich Mean Time (GMT).																										

Field	Description
Country Code	Country code, if configured by the controller
Total Run Time	Total Run time in hours and minutes since last reset or power cycle
Standby Time %	Percent of time the set-top is in standby mode
Low Power Time %	Percent of time the set-top is in Low Power mode, if power saving mode is enabled.

Purchase Status

This diagnostic displays the status of subscriber event purchases on the OSD. The OSD display is updated each time this diagnostic is viewed:

```

                PURCHASE/POLL STATUS
PURCHASES:
UNSENT:          00
UNACK:           00
LAST SEQ NUM:    0000
LAST RB TIME:    N/A

IPPV STATUS:     DISABLED
LAST POLL STATUS
PREP CMD:        0      N/A
PREP ACK:        0      N/A
POLL REQ:        0      N/A
POLL ACK:        0      N/A

STACK LIMIT:    00000010
SHOW COUNT:     00000000
CREDIT TOTAL:   0000010000
DEBIT TOTAL:    0000000000

```

Figure 17: Purchase Status Diagnostic Screen

Table 10: Purchase Status Diagnostic Field Descriptions

Field	Description
Unsent	The number of purchases in the DCX525 remaining to be polled. It can be an integer from 0 to 63.
Unack	The number of reports that have not been acknowledged by the controller. It is an integer.
Last Seq Num	The last acknowledged sequence number of a purchase sent by the controller. It is a 16-bit, unsigned hexadecimal number.
Last RB Time	The last time the DCX525 attempted to report back purchases to the controller, in GPS seconds.
IPPV Status	If IPPV is enabled, the IPPV status indicator is on. If IPPV is disabled, the IPPV status indicator is off.

Field	Description
Prep CMD	"Last Prepare for Poll Command" sequence number and time of the last prepare for poll request command that was sent by the controller. Note that each requesting process maintains an independent sequence of poll requests to uniquely identify the poll responses.
Prep ACK	"Last Prepare for Poll Acknowledge" sequence number and time of the last Report Purchase request sent by the controller.
Poll Request	Sequence number and time of the last send poll buffer command that was sent by the controller.
Poll Acknowledge	Sequence number and time of the last Poll Acknowledge message sent by the controller.
Stack Unit	Unit used in purchase processing.
Show Count	Count used in purchase processing.
Credit Total	Credit used for purchase processing.
Debit Total	Debit used for purchase processing.

Out-Of-Band (OOB) Status

This diagnostic indicates the out-of-band control channel status. The information is updated every five seconds.

OOB STATUS		
OOB FREQUENCY:	075.25 MHz	
CARRIER LOCK:	YES	
DATA:	YES	
EMM DATA:	NO	
SNR:	21.1 dB	GOOD
AGC:	23 %	GOOD
EMM PROVIDER ID:	0x0001	
EMM PID:	0x1503	
NETWORK PID:	0x0777	
HUNT MODE:	Hunted	
LKC:	075.25 MHz	

Figure 18: OOB Status Diagnostic Screen

Table 11: OOB Diagnostic Field Descriptions

Field	Description						
OOB Frequency	Indicates the OOB tuner center frequency, from 70 to 130 MHz.						
Carrier Lock	Indicates whether the OOB receiver is locked to the carrier:						
	<table border="1"> <thead> <tr> <th>OSD</th> <th>Description</th> </tr> </thead> <tbody> <tr> <td>YES</td> <td>Carrier locked</td> </tr> <tr> <td>NO</td> <td>Carrier unlocked</td> </tr> </tbody> </table>	OSD	Description	YES	Carrier locked	NO	Carrier unlocked
OSD	Description						
YES	Carrier locked						
NO	Carrier unlocked						
Data	Indicates whether data is being carried by the OOB and EMM traffic, which is tracked separately:						
	<table border="1"> <thead> <tr> <th>OSD</th> <th>Description</th> </tr> </thead> <tbody> <tr> <td>Yes</td> <td>OOB data detected within the last 5 seconds</td> </tr> <tr> <td>No</td> <td>OOB data not detected within the last 5 seconds</td> </tr> </tbody> </table>	OSD	Description	Yes	OOB data detected within the last 5 seconds	No	OOB data not detected within the last 5 seconds
OSD	Description						
Yes	OOB data detected within the last 5 seconds						
No	OOB data not detected within the last 5 seconds						
EMM Data	Indicates whether EMM data is being carried on the OOB stream:						
	<table border="1"> <thead> <tr> <th>OSD</th> <th>Description</th> </tr> </thead> <tbody> <tr> <td>YES</td> <td>EMM data detected within the last 5 seconds</td> </tr> <tr> <td>NO</td> <td>EMM data not detected within the last 5 seconds</td> </tr> </tbody> </table>	OSD	Description	YES	EMM data detected within the last 5 seconds	NO	EMM data not detected within the last 5 seconds
OSD	Description						
YES	EMM data detected within the last 5 seconds						
NO	EMM data not detected within the last 5 seconds						
SNR	<p>When carrier lock has been established, displays an estimate of the carrier signal-to-noise ratio in dB, with an explanation:</p> <p>GOOD — Good value</p> <p>FAIR — Marginal signal level, check the signal</p> <p>POOR — Unusable signal</p> <p>INVALID — Invalid AGC value</p>						
AGC	<p>When carrier lock has been established, displays an estimate of the AGC as a percentage, with an explanation:</p> <p>GOOD — Good value</p> <p>FAIR — Marginal signal level, check the signal</p> <p>POOR — Unusable signal</p> <p>INVALID — Invalid AGC value</p>						
EMM Provider ID	Displays the conditional access stream for the DCX525 in hexadecimal.						
EMM PID	Displays the packet identifier (PID) stream the DCX525 tunes to for EMM data in hexadecimal.						
Network PID	Displays the network PID to which the DCX525 is tuned to receive network messages in hexadecimal.						
Hunt Mode	The hunt mode includes Hunted None, Round Robin (RR), Search (SRCH), Fixed Frequency (FIX), or EMM Provider ID (EMM).						

Field	Description
LKC	<p>The last known carrier is the last valid OOB frequency displayed in MHz and ranges from 70 to 130 MHz with the specific values of: 75.25, 104.20, 72.75, 92.25, 98.25, 107.25, 107.40, 110.25, 116.25, and 103.75.</p> <p>LKC will remain blank during hunting if a valid carrier has not been found, and will be populated once a valid OOB is found.</p>

Agile OOB Tuner Hunting

An OOB frequency can be selected manually by pressing the Menu button while in the OOB Status diagnostics screen. To exit this mode, press the Menu button a second time, or press the Power button.

If the set-top is in the process of hunting for an OOB frequency, control of frequency selection is suspended, i.e., it is not possible to press the Menu button on the OOB status screen and display MAN FREQ when the set-top is hunting.

Summary of Manual Selection of the OOB Frequency

The manual override frequency capability is only displayed if the box is not currently hunting and the operator presses the MENU key while OOB OSD diagnostics are displayed. The MAN Freq displays the LKC and allows the operator to select (via scroll up/down) a specific frequency to check if a valid OOB is on that specific frequency. The MAN Freq parameter is the OOB frequency selected in the frequency selection mode and displayed in MHz, with the specific values of 75.25, 104.20, 72.75, 92.25, 98.25, 107.25, 107.40, 110.25, 116.25, and 103.75.

1. When in the OOB Receiver Status Diagnostic, press the MENU button to enter the frequency selection mode. The OSD displays a new "MAN FREQ" line at the bottom of the screen, which indicates the last known carrier frequency. At this point, if desired, the frequency change mode can be exited by pressing the MENU key a second time.
2. Use the UP/DOWN channel or cursor keys to scroll through all 10 frequencies until the desired new OOB frequency is found. The new frequency selections appear on the MAN FREQ line of the OSD.
3. When the desired new frequency has been selected, press the SELECT key to start the search. The manual frequency search lasts up to 40 seconds. As the DCX525 searches, on the OSD, the MAN FREQ line of text is cleared, the HUNT MODE displays FIX to indicate a search on a fixed frequency, and the OOB FREQ field changes to the frequency being searched for.
4. If the frequency is found with the proper EMM Provider ID, then the OSD LKC field changes to display the new frequency.
5. If after 40 seconds the frequency search is not successful, the product performs a warm reset.
6. To abort a search without waiting the 40 seconds, the POWER key can be pressed to cause an immediate warm reset.

DOCSIS Set-top Gateway

Note: This section only applies to set-tops with an embedded cable modem (eCM).

```

DOCSIS Set-top Gateway (DSG)
DSG Enabled:      Yes
DSG Mode:         Advanced
Two-Way Mode:    No
Acquired DCD:    Yes
CA Tunnel 1 Acq: Yes
CA Tunnel 2 Acq: Yes
Broadcast Tunnel Acq: Yes
App Tunnel Acquired: Yes
EAS Tunnel Acquired: Yes
EMM Data:        No

Network PID:     0x0777
EMM PID:         0x1503
EMM Provider ID: 0x0001

Carrier Lock:    No
Frequency:       711.00 MHz
Mode:            QAM 256
Power Level:     000 dBmV
SNR:             00.0 dB

```

Figure 19: DSG Status Diagnostic Screen

Table 12: DSG Diagnostic Field Descriptions

Field	Description
DSG Enabled	Indicates current DSG status:
OSD	Description
Yes	STB is using DSG for OOB communication
No	STB is not using DSG for OOB communication
DSG Mode	Indicates the DSG mode the STB is operating in:
OSD	Description
Basic	STB is using Basic mode for DSG
Advanced	STB is using Advanced mode for DSG
Two-Way Mode	Indicates whether the STB is using DSG bi-directionally or only one way:
OSD	Description
Yes	Two-way mode is active, STB is using DSG for both downstream and upstream communication
No	One way mode is active, STB is using DSG for downstream communication only
N/A	Default value or used if value is invalid or cannot be retrieved
Acquired DCD	Indicates if the eCM has acquired the DOCSIS channel descriptor (DCD):

Field	Description
	<p>OSD Description</p> <p>Yes eCM has acquired the DCD</p> <p>No eCM has not acquired the DCD</p> <p>N/A Default value or used if value is invalid or cannot be retrieved</p>
CA Tunnel 1 Acq	Indicates if the eCM has acquired the CA Tunnel 1:
	<p>OSD Description</p> <p>Yes eCM has acquired the CA Tunnel 1</p> <p>No eCM has not acquired the CA Tunnel 1</p> <p>N/A Default value or used if value is invalid or cannot be retrieved</p>
CA Tunnel 2 Acq	Indicates if the eCM has acquired the CA Tunnel 2:
	<p>OSD Description</p> <p>Yes eCM has acquired the CA Tunnel 2</p> <p>No eCM has not acquired the CA Tunnel 2</p> <p>N/A Default value or used if value is invalid or cannot be retrieved</p>
Broadcast Tunnel Acq	Indicates if the eCM has acquired the Broadcast Tunnel :
	<p>OSD Description</p> <p>Yes eCM has acquired the Broadcast Tunnel</p> <p>No eCM has not acquired the Broadcast Tunnel</p> <p>N/A Default value or used if value is invalid or cannot be retrieved</p>
App Tunnel Acq	Indicates if the eCM has acquired the App Tunnel:
	<p>OSD Description</p> <p>Yes eCM has acquired the App Tunnel</p> <p>No eCM has not acquired the App Tunnel</p> <p>N/A Default value or used if value is invalid or cannot be retrieved</p>
EAS Tunnel Acq	Indicates if the eCM has acquired the EAS Tunnel:
	<p>OSD Description</p> <p>Yes eCM has acquired the EAS Tunnel</p> <p>No eCM has not acquired the EAS Tunnel</p> <p>N/A Default value or used if value is invalid or cannot be retrieved</p>
EMM Data	Indicates whether EMM data is being carried on the OOB stream:

Field	Description						
	<table border="1"> <thead> <tr> <th>OSD</th> <th>Description</th> </tr> </thead> <tbody> <tr> <td>Yes</td> <td>EMM data detected within the last 5 seconds</td> </tr> <tr> <td>No</td> <td>EMM data not detected within the last 5 seconds</td> </tr> </tbody> </table>	OSD	Description	Yes	EMM data detected within the last 5 seconds	No	EMM data not detected within the last 5 seconds
OSD	Description						
Yes	EMM data detected within the last 5 seconds						
No	EMM data not detected within the last 5 seconds						
Network PID	Displays the network PID to which the DCX525 is tuned to receive network messages, in hexadecimal.						
EMM PID	Displays the packet identifier (PID) stream the DCX525 tunes to for EMM data, in hexadecimal.						
EMM Provider ID	Displays the conditional access stream for the DCX525, in hexadecimal.						
Carrier Lock	Indicates whether the DSG receiver is locked to the carrier:						
	<table border="1"> <thead> <tr> <th>OSD</th> <th>Description</th> </tr> </thead> <tbody> <tr> <td>Yes</td> <td>Carrier locked</td> </tr> <tr> <td>No</td> <td>Carrier unlocked</td> </tr> </tbody> </table>	OSD	Description	Yes	Carrier locked	No	Carrier unlocked
OSD	Description						
Yes	Carrier locked						
No	Carrier unlocked						
Frequency	Indicates the DSG tuner center frequency. N/A is displayed on the OSD as default or if value is invalid or cannot be retrieved.						
Mode	Indicates the downstream QAM channel mode (QAM 64 or QAM 256). N/A is displayed on the OSD as default or if value is invalid or cannot be retrieved.						
Power Level	Indicates the power level in dBmV. N/A is displayed on the OSD as default or if value is invalid or cannot be retrieved.						
SNR	When carrier lock has been established, displays an estimate of the carrier signal-to-noise ratio in dB. N/A is displayed on the OSD as default or if value is invalid or cannot be retrieved.						

In-Band Status

This diagnostic displays the in band status for the last attempted tuned channel. The information is updated every five seconds.

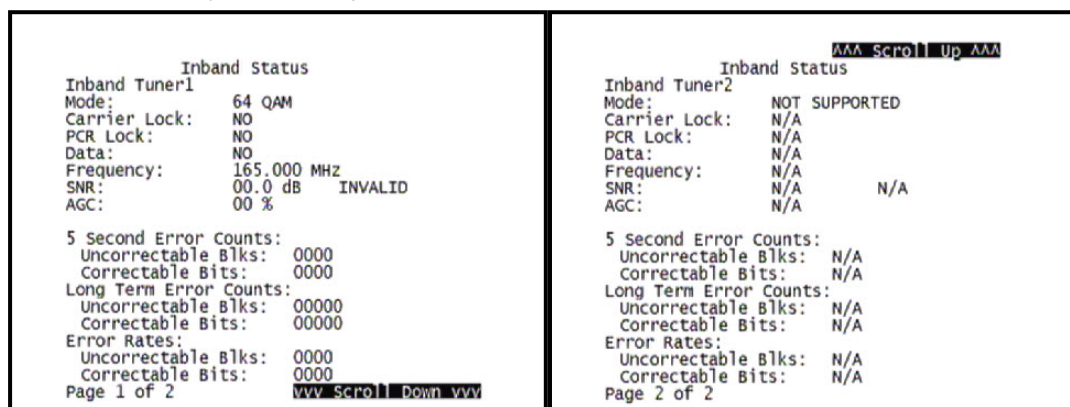

Figure 20: In-Band Status Diagnostic Screens

Table 13: In-Band Status Diagnostic Field Descriptions

Field	Description						
Mode	The values displayed on the OSD are: 64 QAM — 64 QAM digital channel 256 QAM — 256 QAM digital channel						
Carrier Lock	Indicates whether the in-band receiver is locked to the carrier. If a digital carrier is not present, it indicates the carrier is not locked:						
	<table border="1"> <thead> <tr> <th>OSD</th> <th>Description</th> </tr> </thead> <tbody> <tr> <td>Yes</td> <td>Carrier locked</td> </tr> <tr> <td>No</td> <td>Carrier not locked</td> </tr> </tbody> </table>	OSD	Description	Yes	Carrier locked	No	Carrier not locked
OSD	Description						
Yes	Carrier locked						
No	Carrier not locked						
PCR Lock	Indicates whether the in-band receiver is locked to the current program clock reference for a digital video service on the specified tuner. If a digital carrier is not present, it indicates the PCR is not locked.						
Data	Indicates whether data is being carried on the in-band stream. The indicators cover all packet processors regardless of the stream they are monitoring:						
	<table border="1"> <thead> <tr> <th>OSD</th> <th>Description</th> </tr> </thead> <tbody> <tr> <td>YES</td> <td>In-band data detected within the last 5 seconds</td> </tr> <tr> <td>NO</td> <td>In-band data not detected within the last 5 seconds</td> </tr> </tbody> </table>	OSD	Description	YES	In-band data detected within the last 5 seconds	NO	In-band data not detected within the last 5 seconds
OSD	Description						
YES	In-band data detected within the last 5 seconds						
NO	In-band data not detected within the last 5 seconds						
Frequency	The in-band frequency is center RF carrier frequency tuned for the digital service on the specified tuner. The frequency is displayed in MHz in xxxx.xxx format and ranges from 54 to 1002 MHz.						

Field	Description
SNR	<p>When carrier lock has been established, SNR displays an estimate of the carrier signal-to-noise ratio in dB, with an explanation:</p> <p>GOOD — Good value</p> <p>FAIR — Marginal signal level, check the signal</p> <p>POOR — Unusable signal</p> <p>INVALID — Invalid SNR value</p>
AGC	<p>When a carrier lock has been established, ACG displays an estimate of the automatic gain control as a percentage, with the following explanations:</p> <p>GOOD — Good value</p> <p>FAIR — Marginal signal level, check the signal</p> <p>POOR — Unusable signal</p> <p>INVALID — Invalid AGC value</p>
5 Second Error Counts	<p>Indicates the number of correctable and uncorrectable digital multiplex errors. It is updated every five seconds and reset each time the DCX525 is power cycled or another digital multiplex is tuned</p>
Long Term Error Counts	<p>Indicates the number of correctable and uncorrectable digital multiplex errors. It is updated every five seconds and reset every 24 hours, each time the DCX525 is power cycled, or another digital multiplex is tuned.</p>
Error Rates	<p>Indicates the estimated error rates for correctable and uncorrectable multiplex errors. It is updated every 10 minutes and reset each time the DCX525 is power cycled or another digital multiplex is tuned.</p>

Unit Address

This diagnostic displays the unit address of the CableCARD if inserted:

```

UNIT ADDRESS

TVPC INSTALLED:                NO
UNIT ADDRESS: 000-00703-52276-081

OOB ADDRESSES:
NETWORK: 000-00000-00000-000
MULTICAST 16 FOR: NET
                0x0000      0x0000
                0x0000      0x0000

SERIAL NO: M11240TDP558
MAC ADDRESSES:
DOCSIS: 7C BF B1 F8 1C 61
Ethernet: 90 B1 34 02 8E C8
1394: 00 00 00 00 00 00 00 00
USB: 90 B1 34 02 8E CA
Settop: 90 B1 34 02 8E C9

```

Figure 21: Unit Address Diagnostic Screen

Table 14: Unit Address Diagnostic Field Descriptions

Field	Description
TvPC Installed	Indicates whether the TvPC renewable security system is installed: NO — TvPC is not installed (Note: the DCX525 does not include a TvPC slot).
Unit Address	A unique decimal number that indicates the unit address or physical address.
OOB Addresses	
Network	The DCX525 network address displayed in decimal format.

Field	Description
Multicast 16 Address	<p>Specifies the stream to which the OOB multicast 16 addresses are assigned. The stream type and multicast 16 addresses cycle on the OSD every five seconds. The valid stream types nnnn are:</p> <ul style="list-style-type: none">Net — NetworkEMM — EMMSCC — SCC_ECMDnld — DownloadData — DataPoll — Polling packet identifier (PID) <p>The 16-bit multicast address is displayed in 4-byte hexadecimal format. The multicast 16 addressed messages filter on a 16-bit multicast address. The user processor can define up to four multicast addresses in hardware, and any message matching one of the four is processed. Messages not matching the multicast address are discarded.</p>
Serial Number	The Host Serial Number is displayed on the Unit Address diagnostic screen.
MAC Addresses	The MAC addresses are stored in protected flash and displayed in hexadecimal.

Current Channel Status

This diagnostic displays a status of the last attempted channel you attempted to tune on the in-band stream. The channel type determines the status display.

```

CURRENT CHANNEL STATUS
PRIMARY A/V SOURCE: N/A
IB TUNER 1
TYPE: DIGITAL CLR
STATUS: Acquired Not playing
PREVIEW: NO
PURCHASABLE: NO
PURCHASABLE: NO
EPOCH Num: 000
Auth Reason: 0x00
Service: 0 Status: 0 ID:0x000000
CH: 800 Tuned Frequency: 651.0000 MHZ
VCT ID: 1 SOC: DISABLED
CCI: 0x00 APS: 0x00 RC Flag: 0x00
CIT: 0x00 DRM: 0x00 RS: FOREVER

Page 1 of 2 vvv Scroll Down vvv

```

```

CURRENT CHANNEL STATUS ^^^ Scroll Up ^^^
IB TUNER 2
TYPE: DIGITAL ENC
STATUS: Acquired Not playing
PREVIEW: NO
PURCHASABLE: NO
PURCHASABLE: NO
EPOCH Num: 026
Auth Reason: 0x07
Service: 0 Status: 1 ID:0x020000
CH: 381 Tuned Frequency: 567.0000 MHZ
VCT ID: 1
CCI: 0x02 APS: 0x00 RC Flag: 0x00
CIT: 0x00 DRM: 0x00 RS: FOREVER

Page 2 of 2

```

```

SDV Client Status ^^^ Scroll Up ^^^
Status: UnInited
Pri Svr: 0.0.0.0/0
Sec Svr: 0.0.0.0/0
Dsc Srv: 0.0.0.0/0
Mode: OB-OB
MotoCar: xxxxx Cnt=dddd
Config: Ver=255,MRS=9999
Channels: Sw=0 ACL=0
Carousel: Ver=255,MRS=9999
Last Err: 11 4 2010 19:24:18
Last Err: RES(03E0)
Service Group: 0

Frq TSID SG Tunes/Fail/Fail
Short Long

Page 3 of 3

```

Figure 22: Current Channel Status Diagnostic Screens

Table 15: Current Channel Status Diagnostic Field Descriptions

Field	Description												
Type	Indicates whether the channel is analog or digital.												
	<table border="1"> <thead> <tr> <th>OSD</th> <th>Description</th> </tr> </thead> <tbody> <tr> <td>DIGITAL</td> <td>Digital</td> </tr> </tbody> </table>	OSD	Description	DIGITAL	Digital								
OSD	Description												
DIGITAL	Digital												
Status	Indicates the current status of channel acquisition.												
	<table border="1"> <thead> <tr> <th>OSD</th> <th>Description</th> </tr> </thead> <tbody> <tr> <td>Acquired</td> <td>Service has been acquired and is playing, but stream components may not be locked yet if the service is digital. For an analog service, there are no stream components to lock, so this is the final status.</td> </tr> <tr> <td>Acquiring</td> <td>Service is being reacquired.</td> </tr> <tr> <td>Not Acquired</td> <td>Service has not been acquired due to a failure.</td> </tr> <tr> <td>Acquired and Locked</td> <td>Digital service has been acquired, and all relevant stream components for the service are locked. If the service is purchasable, the stream components will not be locked until the service is purchased.</td> </tr> <tr> <td>Acquired Not Playing</td> <td>Service has been partially acquired, but is not playing. For MPEG-2 services, this means that no components are selected.</td> </tr> </tbody> </table>	OSD	Description	Acquired	Service has been acquired and is playing, but stream components may not be locked yet if the service is digital. For an analog service, there are no stream components to lock, so this is the final status.	Acquiring	Service is being reacquired.	Not Acquired	Service has not been acquired due to a failure.	Acquired and Locked	Digital service has been acquired, and all relevant stream components for the service are locked. If the service is purchasable, the stream components will not be locked until the service is purchased.	Acquired Not Playing	Service has been partially acquired, but is not playing. For MPEG-2 services, this means that no components are selected.
OSD	Description												
Acquired	Service has been acquired and is playing, but stream components may not be locked yet if the service is digital. For an analog service, there are no stream components to lock, so this is the final status.												
Acquiring	Service is being reacquired.												
Not Acquired	Service has not been acquired due to a failure.												
Acquired and Locked	Digital service has been acquired, and all relevant stream components for the service are locked. If the service is purchasable, the stream components will not be locked until the service is purchased.												
Acquired Not Playing	Service has been partially acquired, but is not playing. For MPEG-2 services, this means that no components are selected.												
Preview	Indicates whether the current program is in preview mode.												
Purchasable	Indicates whether the current program can be purchased for viewing.												
Purchased	Indicates whether the current program has been purchased.												
EPOCH Num	Number of authorization requests originating from DCX525.												
Auth Reason	The current epoch authorization reason is displayed in the hexadecimal format 0xbb on the OSD.												
Service	Service number from the secure processor. It is a decimal value from 0 to 3.												
Status	Service status from the secure processor. It is a decimal value from 0 to 3.												
ID	Service ID from the secure processor. It is a hexadecimal value. First 2 bytes indicate a MPEG service number, and the last byte indicates another unique identifier.												
CH	Current Channel to which the set-top is tuned.												
Tuned Frequency	(Digital channels only) The center RF carrier frequency for the digital service. It can be From 54 to 860 MHz.												
VCT ID	Virtual Channel Table ID												
SOC	The Selectable Output control is enabled or disabled.												
CCI	The copy control information:												

Field	Description
	00 — copy free 01 — no more copies 10 — copy once 11 — never copy N/A — the value is invalid or cannot be retrieved
APS	The Analog Protection System; for example, Rovi®: 00 — no Rovi 11 — Type 3 Rovi N/A — the value is invalid or cannot be retrieved
RC Flag	Displays whether the broadcast flag is present: 0 — no flag/not defined 1 — the flag is present/enabled N/A — the value is invalid or cannot be retrieved
CIT	The constrained image trigger, as delivered in the PRK or the Set DRM API: 1 — set 0 — not set N/A — the value is invalid or cannot be retrieved
DRM	The digital rights management valid flag bit: 1 — set 0 — not set N/A—the value is invalid or cannot be retrieved
RS	The retention state: Forever, 1 week, 2 days, 1 day, 12 hours, 6 hours, 3 hours, 90 minutes, or Not Defined N/A —value is invalid or cannot be retrieved

Field	Description
SDV Client Status	<p>If Switched digital video is available, the following information is related to the SDV Client:</p> <ul style="list-style-type: none"> • Status of client • IP Address of primary switched video manager (SVM) server • IP Address of secondary switched video manager (SVM) server • IP Address of Auto Discovery server • SDV Mode • MotoCar configuration and message count • Version number of the SDV configuration message and number of minutes since the version was last seen by the client • Configured switched channels (SW) followed by the number of channels in the Active Channel List (ACL). • Version number of the Mini Carousel message and the time it was last seen • Time and date of the last error recorded by the Client • Last error code • Service Group ID • SDV QAM diagnostic parameter table consisting of entries for attempted and successful SDV tunes and QAMs listed in the Auto Discover list. Table includes the QAM frequency, the TSID, ("*" if a TSID mismatch exists), Auto Discovery Indicator, if QAM is included in the Auto Discover List, Service group ID, count of successful tunes to switched services, count of short term tune failures over the last 24 hours, count of long term tune failures.

RF Modem (Upstream)

This diagnostic displays the RF modem status, if an RF modem is installed in the DCX525. The information is updated each time the DCX525 displays this diagnostic.

RF MODEM	
STATUS:	CONFIGURED
CENTER FREQUENCY:	0008.096 MHZ
REQUESTED POWER LEVEL:	060 dB
ACTUAL POWER LEVEL:	INVALID
REPORT BACK ADDRESS:	0x000005

Figure 23: RF Upstream Modem Diagnostic Screen

Table 16: RF Upstream Modem Diagnostic Field Descriptions

Field	Description
Status	CONFIGURED or NOT CONFIGURED.
Center Frequency	The RF modem center frequency is displayed on the OSD MHz.
Requested Power Level	The value in dB assigned to the DCX525 during RF leveling (which is blank if it is not configured).
Actual Power Level	The power level is displayed in dB on the OSD or is blank if the power level has not been set.
Report Back Address	Displayed in 4 byte hexadecimal format, if configured.

Code Modules

This diagnostic includes information about the firmware loaded in flash memory and all non-volatile code versions that are installed on the DCX525. When the native suite is running, the diagnostics of the application operating system and all associated objects should be accessible.

```

ASTB INVD
Boot Code: 02.00
Platform Built: Version: 3261e
Mar 31 2013 16:29:03
Digital Secure Processor: M01
Analog Secure Processor: N/A

Object Ver Status ID LO
029_IReE 32.61 ENABLED FFFF 0

```

Figure 24: Code Modules Diagnostic Screen

Table 17: Code Modules Diagnostic Field Descriptions

Field	Description									
Boot Code	The boot code version in ASCII format.									
Platform Built	The date platform software was built.									
Version	The firmware version and build date in ASCII format.									
Processor	The digital secure processor version in ASCII format.									
Analog Secure Processor	The analog secure processor version in ASCII format.									
Downloadable Object Information Table	Lists all objects loaded, or being loaded, onto the DCX525 in ASCII format. The information displayed for each object depends on the running environment.									
Boot Code	The boot code version in ASCII format.									
Object	The object name.									
Ver	The object version.									
Status	The object status, updated on the OSD every five seconds while you display the diagnostic:									
	<table border="1"> <thead> <tr> <th>OSD</th> <th>Status</th> <th>Description</th> </tr> </thead> <tbody> <tr> <td>MEM ALLOC</td> <td>Allocated</td> <td>Memory for the object is allocated.</td> </tr> <tr> <td>LOADING</td> <td>Loading</td> <td>The Object is being loaded.</td> </tr> </tbody> </table>	OSD	Status	Description	MEM ALLOC	Allocated	Memory for the object is allocated.	LOADING	Loading	The Object is being loaded.
OSD	Status	Description								
MEM ALLOC	Allocated	Memory for the object is allocated.								
LOADING	Loading	The Object is being loaded.								

Field	Description		
	STARTING	Enabling	The Object is being started (the constructor is running).
	ENABLED	Enabled	The Object is running.
	ENA-NOT RUN	Enabled_Not_Runnable	The Object is enabled, but cannot run.
	STOPPING	Disabling	The Object is being stopped (the destructor is running).
	DISABLED	Disabled	The Object has been disabled.
	DIS-NOT RUN	Disabled_Not_Runnable	The Object is disabled and cannot run.
	DELETING	Deleting	The Object is being deleted.
	POSTPONED	Postponed	The Object cannot run on the current system; it will be enabled during the next boot.
	CONNECTED	Connect	Connected to download PID — awaiting data.
	PEND CONNECT	TryingToConnect	Trying to connect.
ID	The object identifier.		
LO	The Local Origination states whether the object is located locally on the set-top.		

Memory Configuration

This diagnostic displays the DCX525 memory configuration. The information is updated when you display the diagnostic.

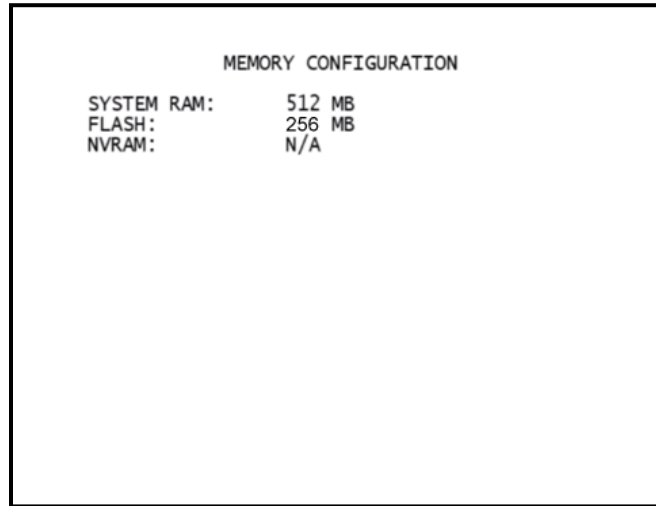

Figure 25: Memory Configuration Diagnostic Screen

Table 18: Memory Configuration Diagnostic Field Descriptions

Field	Description
System RAM	The allocated system RAM in MB.
Flash	The allocated flash memory in MB.
NVRAM	The allocated NVRAM in KB.

Audio/Video Status

Audio/Video Status diagnostics display information regarding audio and video content and settings configured for the set-top.

```

          AUDIO / VIDEO STATUS
SPDIF: IEC958PCM          LFE: 0
Dolby Volume: OFF
Audio Mute: ON
Video Mute: MUTED
Captions Detected:      N/A
N/A                       Primary Lang
Digital Subtitles Status
Enabled: NO              ISO Lang: eng
Enhanced: NO            Rendered: NO
PiP Focus: N/A
OUTPUT FORMAT:          NTSC
INPUT SOURCE:           IB TUNER 1
ADP LOCK:
AUDIO MODE:             N/A
VP LOCK:
INPUT FORMAT:           N/A

3D Mode: AUTO          SEI = NA
3D Format: 2D

```

Figure 26: Audio/Video Status Diagnostic Screen

Table 19: Audio/Video Status Diagnostic Field Descriptions

Field	Description
S/PDIF Output	Indicates S/PDIF Mode as set by application software.
OSD	Description
N/A	Audio S/PDIF mode is not applicable.
IEC958PCM	PCM audio selected.
Dolby Digital	Dolby Digital uses the following speaker selections:
1/0	Right front or left front
2/0	Right front and left front
3/0	Right front and left front and center
2/1	Right front and left front and (right rear or left rear)
3/1	Right front and left front and center & (right rear or left rear)
2/2	Right front and left front and right rear and left rear
3/2	Right front and left front and center and right rear & left rear
LFE: Low Frequency	The LFE indicates if the nomenclature low frequency effects are available in the

Field	Description												
Effect	Dolby Digital audio stream, as indicated if the "0.1" is present in the Dolby Digital 5.1 nomenclature (for example, "Dolby Digital 5.1 surround"). Valid values include:												
	<table border="1"> <thead> <tr> <th>OSD</th> <th>Description</th> </tr> </thead> <tbody> <tr> <td>0</td> <td>LFE is not available</td> </tr> <tr> <td>1</td> <td>LFE is available (i.e. "Dolby Digital 5.1 surround").</td> </tr> </tbody> </table>	OSD	Description	0	LFE is not available	1	LFE is available (i.e. "Dolby Digital 5.1 surround").						
OSD	Description												
0	LFE is not available												
1	LFE is available (i.e. "Dolby Digital 5.1 surround").												
Dolby Volume	Indicates if Dolby Volume is turned on or off												
Audio / Video Mute	The Audio and Video Mute Status indicates if the audio and/or video have been muted by the software. The audio mute is either On or Off. The Video Mute describes the MPEG muting method selected by the software and indicates if the output video is in the mute state by displaying On or Off, followed by the mute method. Methods include:												
	<table border="1"> <thead> <tr> <th>OSD</th> <th>Description</th> </tr> </thead> <tbody> <tr> <td>UNMUTED</td> <td>Displayed if the mute method is not selected.</td> </tr> <tr> <td>MUTE to STILL</td> <td>Displayed if the mute method includes stopping video and presenting a still frame, similar to a pause function.</td> </tr> <tr> <td>MUTE to BLACK</td> <td>Displayed if mute method presents a black screen.</td> </tr> </tbody> </table>	OSD	Description	UNMUTED	Displayed if the mute method is not selected.	MUTE to STILL	Displayed if the mute method includes stopping video and presenting a still frame, similar to a pause function.	MUTE to BLACK	Displayed if mute method presents a black screen.				
OSD	Description												
UNMUTED	Displayed if the mute method is not selected.												
MUTE to STILL	Displayed if the mute method includes stopping video and presenting a still frame, similar to a pause function.												
MUTE to BLACK	Displayed if mute method presents a black screen.												
Captions	The captions mode displays captions present on the service. <i>Note: The caption options are set via the User Setting Menu, where the subscriber can enable closed captions and select options.</i>												
1st Caption Row: Caption Detected:													
	<table border="1"> <thead> <tr> <th>OSD</th> <th>Description</th> </tr> </thead> <tbody> <tr> <td>708</td> <td>EIA-708 captions detected.</td> </tr> <tr> <td>608</td> <td>EIA-608 captions detected.</td> </tr> <tr> <td>608 and 708</td> <td>Both EIA-608 and EIA-708 captions detected.</td> </tr> <tr> <td>None</td> <td>No captions detected.</td> </tr> </tbody> </table>	OSD	Description	708	EIA-708 captions detected.	608	EIA-608 captions detected.	608 and 708	Both EIA-608 and EIA-708 captions detected.	None	No captions detected.		
OSD	Description												
708	EIA-708 captions detected.												
608	EIA-608 captions detected.												
608 and 708	Both EIA-608 and EIA-708 captions detected.												
None	No captions detected.												
2nd Caption Row: Caption Options Set, followed by Service Selected:													
	<table border="1"> <thead> <tr> <th>OSD</th> <th>Description</th> </tr> </thead> <tbody> <tr> <td>708 Set</td> <td>EIA-708 captions enabled, with options set by user.</td> </tr> <tr> <td>708 Default</td> <td>EIA-708 captions enabled, with no options set by user.</td> </tr> <tr> <td>608 Set</td> <td>EIA-608 captions enabled, with options set by user.</td> </tr> <tr> <td>608 Default</td> <td>EIA-608 captions enabled, with no options set by user.</td> </tr> <tr> <td>None Set</td> <td>Captions detected but not enabled.</td> </tr> </tbody> </table>	OSD	Description	708 Set	EIA-708 captions enabled, with options set by user.	708 Default	EIA-708 captions enabled, with no options set by user.	608 Set	EIA-608 captions enabled, with options set by user.	608 Default	EIA-608 captions enabled, with no options set by user.	None Set	Captions detected but not enabled.
OSD	Description												
708 Set	EIA-708 captions enabled, with options set by user.												
708 Default	EIA-708 captions enabled, with no options set by user.												
608 Set	EIA-608 captions enabled, with options set by user.												
608 Default	EIA-608 captions enabled, with no options set by user.												
None Set	Captions detected but not enabled.												
	<table border="1"> <thead> <tr> <th>OSD</th> <th>Definition</th> </tr> </thead> </table>	OSD	Definition										
OSD	Definition												

Field	Description
CC 1	Closed Caption service CC 1 (default)
CC 2	Closed Caption service CC 2
CC 3	Closed Caption service CC 3
CC 4	Closed Caption service CC 4
T 1	Closed Caption service T 1
T 2	Closed Caption service T 2
T 3	Closed Caption service T 3
T 4	Closed Caption service T 4
OSD	Description
Primary Lang	Primary language set by the provider (default, Service 1).
Second Lang	Secondary language set by the provider (Service 2).
Service 3	Set by the provider Service 3.
Service 4	Set by the provider Service 4.
Service 5	Set by the provider Service 5.
Service 6	Set by the provider Service 6.
Digital Subtitle Status	<p>The subtitle parameter indicates if subtitles are enabled and, if enabled, what language is selected and if the subtitle is being rendered. The language is displayed as the 3-character ISO639.2/B language code.</p> <ul style="list-style-type: none"> • Enabled is indicated with Yes or No. • The language is displayed as the 3-character ISO639.2 language code. • Enhanced mode is indicated with Yes or No. • Rendered status is indicated with Yes or No.
Output Format	Standard used for the output format if available, i.e. NTSC video standard

Field	Description
Input Sources	<p>The input source list information on ADP Lock, Audio Mode, VP lock, and Input Format.</p> <p>The ADP Lock indicates whether the audio stream is locked. Valid values are:</p> <ul style="list-style-type: none">• YES: Audio Processor is locked to the audio stream.• NO: Audio Processor is not locked to the audio stream. <p>Audio Mode indicates the audio Mode of in incoming digital service. Valid values include:</p> <ul style="list-style-type: none">• N/A: The audio mode is not applicable to the currently tuned stream.• Mono: The audio mode is monophonic.• Stereo: The audio mode is stereo.• Surround: The audio mode is surround sound.• 5.1: The audio mode is Dolby® Digital 5.1 Surround Sound. <p>VP Lock indicates whether the video stream is locked. Valid values are:</p> <ul style="list-style-type: none">• YES: Video Processor is locked to the video stream.• NO: Video Processor is not locked to the video stream. <p>The input format includes the aspect ratio (4:3 or 16:9), the screen pixel size (nnnnXnnnn), pixel display ('i' for interlaced, 'p' for progressive), and frames per second (24, 25, 30, or 60).</p>

Interface Status

The Interface Status diagnostic displays when running in Thin Client. There is no LED display. The information on the OSD is updated when you display the diagnostic.

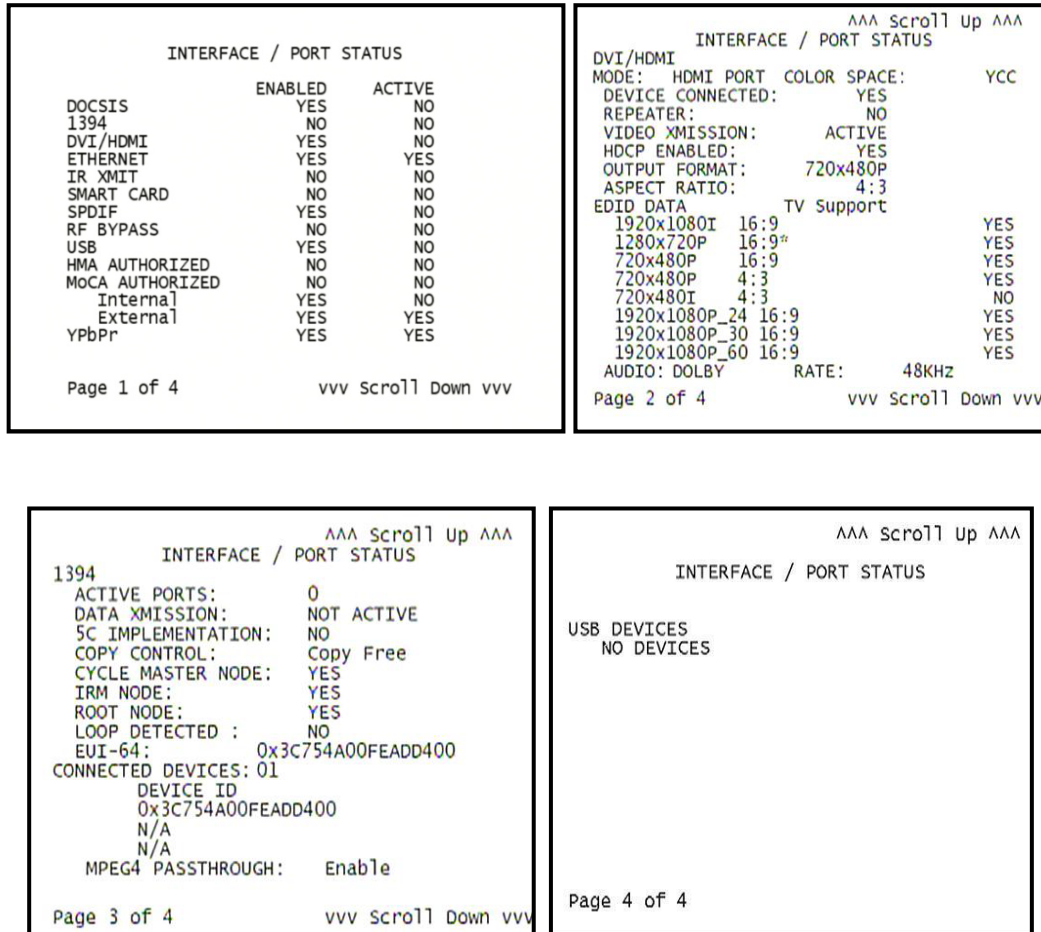

Figure 27: Interface Status Diagnostic Screens

Table 20: Interface Status Diagnostic Field Descriptions

Field	Description
1394 I/O Device	Indicates if enabled; indicates if active.
USB I/O Device	Indicates if enabled; indicates if active.
Ethernet Device	Indicates if enabled; indicates if active.
IR Xmit	Indicates if enabled; indicates if active.

Field	Description
Hard Drive Status	Indicates if enabled; indicates if active.
Smart Card	Indicates if enabled; indicates if active.
HDMI Port	<p>If a device is connected to the HDMI port only, the following diagnostics display to help troubleshoot the HDMI interface. They all display "N/A" if no device is connected to the HDMI port, or if the value is invalid or cannot be retrieved.</p> <ul style="list-style-type: none"> • Device Connected — Indicates whether a device is connected to the HDMI port—Yes or No. • Repeater — Indicates whether the connected device is a repeater — Yes or No. • Video Xmission (transmission) — Indicates whether the DCX525 is transmitting video over the HDMI port — Not Active or Active. • HDCP Enabled — Indicates whether the DCX525 is using HDCP to encrypt video transmitted over the HDMI link — Yes or No. If the Video Xmission status is Not Active, the HDCP Enabled status is No. • Output Format — Indicates the timing format of the video sent through HDMI: <ul style="list-style-type: none"> ○ 1920 x 1080i — 1920 pixels wide by 1080 pixels high, interlaced ○ 1280 x 720p — 1280 pixels wide by 720 pixels high, progressive ○ 720 x 480p — 720 pixels wide by 480 pixels high, progressive ○ 720 x 480i — 720 pixels wide by 480 pixels high, interlaced ○ 640 x 480p — 640 pixels wide by 480 pixels high, progressive <p>Aspect Ratio — Indicates the aspect ratio of the video sent through HDMI — 4:3 or 16:9.</p>
EDID Data	<p>Indicates the video timing formats that were read from the Extended Display Identification Data (EDID) register for the connected device, in particular the detailed timing description blocks. The list displays all of the formats that the DCX525 could read, up to a maximum of 12 formats. If the DCX525 cannot read any formats, EDID Data is blank. An asterisk (*) after the aspect ratio means the DCX525 supports the format. If more than twelve video timing formats are discovered, the supported formats only are listed first, followed by up to twelve remaining formats.</p>

User Setting Status

This diagnostic shows the current User Settings.

USER SETTING STATUS	
TV TYPE:	16:9
YPbPr OUTPUT	NATIVE
4:3 OVERRIDE	OFF
CLOSED CAPTION	ENABLED
SERVICE SELECTION	
ANALOG	CC1
DIGITAL	PRIMARY LANG
FONT SIZE	AUTO
FONT STYLE	AUTO
FONT COLOR	AUTO
FONT OPACITY	AUTO
FONT EDGE TYPE	AUTO
FONT EDGE COLOR	AUTO
BACKGROUND COLOR	AUTO
BACKGROUND OPACITY	AUTO
SETTINGS	AUTO
AUTO POWER DOWN	4 HOURS

Figure 28: User Setting Status Diagnostic Screen

DOCSIS Status

Note: This section only applies to set-tops with an embedded cable modem (eCM).

This four-screen diagnostic displays status information for the embedded cable modem (eCM):

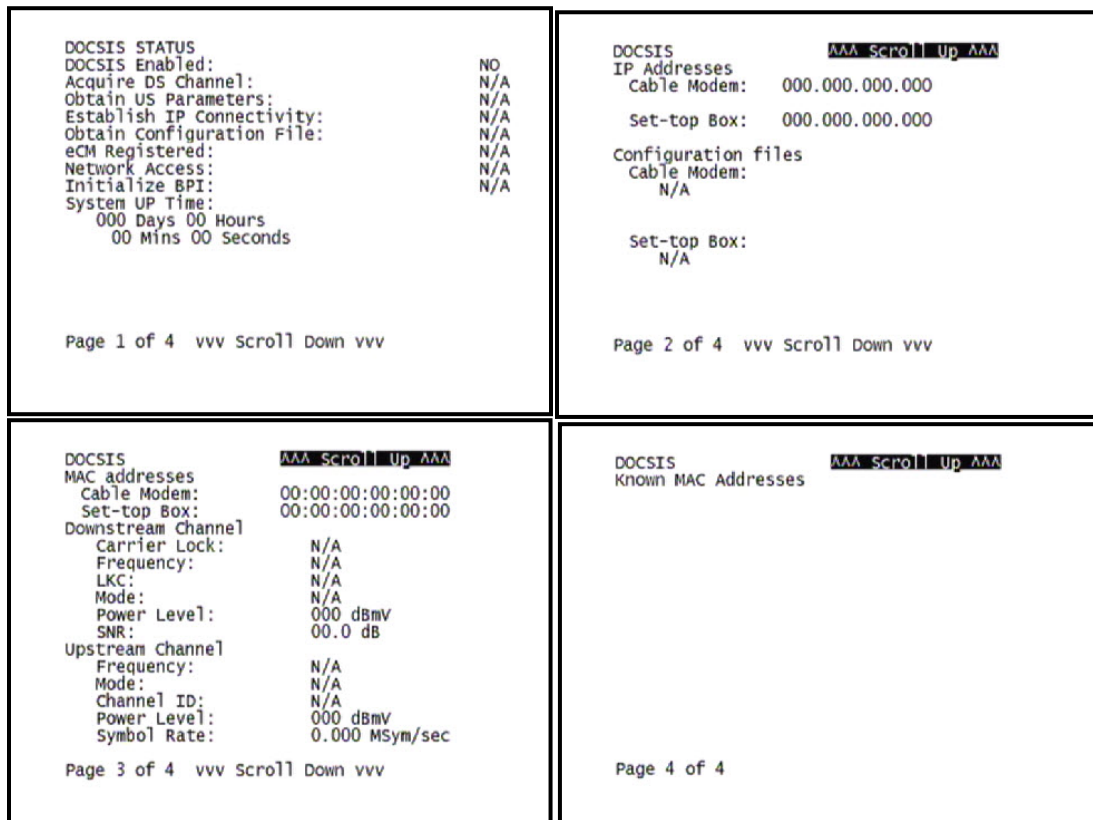

Figure 29: DOCSIS Status Diagnostic Screens

Table 21: DOCSIS Status Diagnostic Field Descriptions

Field	Description
DOCSIS Enabled	For a DOCSIS-enabled set-top, YES. Otherwise, NO.
Acquire DS Channel	The DOCSIS downstream channel acquisition status: <ul style="list-style-type: none"> • YES — The downstream channel is acquired. • NO — The set-top is acquiring the downstream channel. • N/A — The value is invalid, cannot be retrieved, or DOCSIS is not enabled.
Obtain US Parameters	The DOCSIS upstream channel descriptor (UCD) acquisition status: <ul style="list-style-type: none"> • YES — The UCD is acquired. • NO — The set-top is acquiring the UCD or the downstream channel.

Field	Description
	<ul style="list-style-type: none"> • N/A — The value is invalid or cannot be retrieved, or DOCSIS is not enabled.
Establish IP Connectivity	<p>Displays whether the cable modem has acquired its IP address, typically from a Dynamic Host Configuration Protocol (DHCP) server:</p> <ul style="list-style-type: none"> • YES — The IP address is acquired. • NO — The set-top is acquiring its IP address. • N/A — The value is invalid or cannot be retrieved, or DOCSIS is not enabled.
Obtain Configuration File	<p>Displays whether the cable modem has downloaded its DOCSIS cable modem configuration file from the TFTP server:</p> <ul style="list-style-type: none"> • YES — The cable modem configuration file has been successfully downloaded. • NO — The set-top is downloading its cable modem configuration file. • N/A — The value is invalid or cannot be retrieved, or DOCSIS is not enabled.
eCM Registered	<p>Displays whether the embedded cable modem has registered with the cable modem termination system (CMTS):</p> <ul style="list-style-type: none"> • YES — DOCSIS registration is complete. • NO — DOCSIS registration is in progress, or the set-top could not register. • N/A — The value is invalid or cannot be retrieved, or DOCSIS is not enabled.
Network Access	<p>Displays whether the cable modem has been granted access to the DOCSIS network:</p> <ul style="list-style-type: none"> • YES — The cable modem was granted DOCSIS network access. • NO — The set-top is obtaining DOCSIS network access. • N/A — The value is invalid or cannot be retrieved, or DOCSIS is not enabled.
Initialize BPI	<p>The Baseline Privacy Interface (BPI) status:</p> <ul style="list-style-type: none"> • YES — BPI has been successfully initialized for the cable modem. • NO — BPI initialization is in progress, has failed, or was not requested by the network. • N/A — The value is invalid or cannot be retrieved, or DOCSIS is not enabled.
System Up Time	<p>The Days, Hours, Mins (minutes), and Seconds the DOCSIS system has been operational. If the value is invalid or cannot be retrieved, or if DOCSIS is not enabled, each field displays zeros.</p>
IP Addresses	<p>The Cable Modem and Set-Top IP addresses in dotted-decimal format xxx.xxx.xxx.xxx. Each byte value is padded with zeros when necessary. For example, 10.0.1.10 is displayed as 010.000.001.010. If the value is invalid or cannot be retrieved, or if DOCSIS is not enabled, 000.000.000.000 is displayed.</p>
MAC Addresses	<p>The Cable Modem and Set-Top MAC address in hexadecimal format xx:xx:xx:xx:xx:xx. Each byte value xx ranges from 00 to FF and is padded with zeros when necessary. For example, 0:0:2D:1:F1:D is displayed as 00:00:2D:01:F1:0D. If the value is invalid or cannot be retrieved, or if DOCSIS is not enabled, 00:00:00:00:00:00 is displayed.</p>
Downstream Channel (carries data from the headend to the set-top)	

Field	Description
Carrier Lock	<ul style="list-style-type: none"> • YES — The cable modem is locked to a DOCSIS downstream channel. • NO — The cable modem is not locked to a downstream channel. • N/A — The value is invalid or cannot be retrieved, or DOCSIS is not enabled.
Frequency	The center frequency of the channel to which the DOCSIS downstream channel receiver is tuned. It can be 54 to 860 MHz. If the value is invalid or cannot be retrieved, downstream Carrier Lock is No; if DOCSIS is not enabled, N/A is displayed.
LKC	The last known carrier (LKC); the frequency of the last tuned downstream channel used if the embedded cable modem enters hunt mode. It can be 54 to 860 MHz. If the value is invalid or cannot be retrieved, Carrier Lock is No; if DOCSIS is not enabled, N/A is displayed.
Mode	The DOCSIS downstream channel modulation: QAM 64 or QAM 256. If the value is invalid or cannot be retrieved, Carrier Lock is No; if DOCSIS is not enabled, 000 is displayed.
Power Level	The downstream channel power level in dBmV. If the value is invalid or cannot be retrieved, Carrier Lock is No; if DOCSIS is not enabled, 000 is displayed.
SNR	The estimated downstream channel carrier signal-to-noise ratio in the format xx.x dB. It is the value reported as SNR in the MIB. If the value is invalid or cannot be retrieved, Carrier Lock is No; if DOCSIS is not enabled, 00.0 is displayed.
Upstream Channel (carries data from the set-top to the headend)	
Frequency	The center frequency of the channel to which the DOCSIS upstream channel receiver is tuned. It can be 5 to 42 MHz. If the value is invalid or cannot be retrieved, Carrier Lock is No; if DOCSIS is not enabled, N/A is displayed.
Mode	The DOCSIS upstream channel modulation: QPSK, QAM 8, QAM 16, QAM 32, QAM 64, or QAM 128. If the value is invalid or cannot be retrieved, or if DOCSIS is not enabled, N/A is displayed.
Channel ID	The upstream channel identifier 0 to 255. If the value is invalid or cannot be retrieved, or if DOCSIS is not enabled, N/A is displayed.
Power Level	The upstream channel power level in dBmV. If the value is invalid or cannot be retrieved, or if DOCSIS is not enabled, 000 is displayed.
Symbol Rate	The upstream channel symbol rate in mega-symbols per second. If the value is invalid or cannot be retrieved, or if DOCSIS is not enabled, 0.000 is displayed.
Known MAC Addresses	Displays up to 32 MAC addresses learned by the DCX3210 cable modem, including the Set-Top MAC and future MAC addresses assigned by DSG, in hexadecimal format xx:xx:xx:xx:xx:xx on two screens if necessary. If the value is invalid or cannot be retrieved, or if DOCSIS is not enabled, no values are displayed.

Application Specific Information

This diagnostic displays information about application servers:

```

APPLICATION SPECIFIC INFORMATION
NO ADDITIONAL INFORMATION
SERVER 1 NAME:
SRV 1 IP ADDR:
SERVER 2 NAME:
SRV 2 IP ADDR:
SERVER 3 NAME:
SRV 3 IP ADDR:
SERVER 4 NAME:
SRV 4 IP ADDR:
SERVER 5 NAME:
SRV 5 IP ADDR:

```

Figure 30: Application Specific Information Diagnostic Screen

Table 22: Application Specific Information Diagnostic Field Descriptions

Field	Description
Server# Name	The application server name of up to 14 alphanumeric characters. It is blank if the value is invalid or no value can be retrieved.
Srvr # IP Addr	The application server's IP address in dotted-decimal format xxx.xxx.xxx.xxx; the range of each xxx is from 0 to 255. It is blank if the value is invalid or no value can be retrieved.

Interactive Status

This diagnostic describes the interactive information that is displayed only when the Thin Client platform is running. The information on the OSD is updated at least once every five seconds while the diagnostic is displayed. This is an example of a code module display with status descriptions:

```

INTERACTIVE STATUS
IP ADDRESS:      000.000.000.000
UPM:            00000017
UPSTREAM ID:    0000
DOWNSTREAM ID: 0000
STATE:         UNCONFIG
MAC ABORT CNTR: 0000

SOCKET PORT STATE:
00   UNUSED    08   UNUSED
01   UNUSED    09   UNUSED
02   UNUSED    10   UNUSED
03   UNUSED    11   UNUSED
04   UNUSED    12   UNUSED
05   UNUSED    13   UNUSED
06   UNUSED    14   UNUSED
07   UNUSED

```

Figure 31: Interactive Status Diagnostic Screen

Table 23: Interactive Status Diagnostic Field Descriptions

Field	Description						
IP Address	The IP address in dotted decimal format xxx.xxx.xxx.xxx assigned by the NC 1500 to the DCX525. 0.0.0.0 is displayed if the IP address is not configured or unknown.						
UPM	The upstream modem address value is the same as the terminal ID assigned by the DAC 6000. It is a unique, system generated, eight-digit integer between 1 and 16777215. 00000000 is displayed when the UPM is not configured or if it is unknown.						
Upstream ID	A four-digit decimal value from 0000 to 9999 assigned by the DAC 6000 to the DCX525. 0000 is displayed if the Upstream ID is not configured or if it is unknown.						
Downstream ID	A four-digit decimal value from 0000 to 9999 assigned by the DAC 6000 to the DCX525. 0000 is displayed if the Downstream ID is not configured or if it is unknown.						
State	The interactive status of the DCX525:						
	<table border="1"> <thead> <tr> <th>OSD</th> <th>Description</th> </tr> </thead> <tbody> <tr> <td>UNCONFIG</td> <td>The DCX525 is not configured for the interactive system, and the platform should run as pre-interactive.</td> </tr> <tr> <td>MAC_CONNECT</td> <td>The DCX525 is waiting to establish a connection to the</td> </tr> </tbody> </table>	OSD	Description	UNCONFIG	The DCX525 is not configured for the interactive system, and the platform should run as pre-interactive.	MAC_CONNECT	The DCX525 is waiting to establish a connection to the
OSD	Description						
UNCONFIG	The DCX525 is not configured for the interactive system, and the platform should run as pre-interactive.						
MAC_CONNECT	The DCX525 is waiting to establish a connection to the						

Field	Description
	MAC PID Stream.
OSD	Description
INIT_WAIT_DC_OR_C	The DCX525 is in the interactive initialization state and waiting for the default configuration or the contention channel list messages.
WAIT_LM_ACK	The DCX525 is in the interactive initialization state and waiting for Link Management Response ACK for Local Address Message.
WAIT_SO_ACK	The DCX525 is in the interactive initialization state and waiting for a Sign On acknowledgement.
WAIT_LA_OR_SO	The DCX525 is in the interactive initialization state and waiting for Logical Address or Sign On with verification Frequency message.
INIT_STOPPED	The DCX525 is in the interactive initialization state and the TransMode has stopped.
RUN_WAIT_DC_OR_C	The DCX525 is in the interactive state and waiting for the default configuration or the contention channel list messages.
RUNNING	Interactive state is running, sending idle messages, and waiting for any prepare for poll or MAC messages.
RUN_STOPPED	The interactive run state has stopped and DCX525 is waiting for status or a transmission control message.
INVALID	The interactive state is unknown or invalid.
MAC Abort Cntr	This counter increments every time the MAC layer reaches the cell abort count limit. It is reset by the successful upstream transmission of a cell: for example, when the DCX525 receives an ACK. If the counter reaches the MAC abort count limit, the DCX525 assumes the MAC layer is unavailable due to noise, congestion, or some other problem. The DCX525 stops transmitting data upstream, reports an error to the calling function, and attempts to re-enter the network using the initialization process. 0000 is displayed as the default or the MAC Abort CNTR is unconfigured or unknown.
Socket Port State	The socket mode and activity: UNUSED — The socket is not being used. OPENED — The socket is open. READY — The socket is ready to send or receive. RECEIVING — The socket is receiving data from the application server. SENDING — The socket is sending data to the application server. UNKNOWN — The socket state is invalid or unknown.

Connected Home

Note: This section only applies to set-tops with MoCA functionality.

This three screen diagnostic displays the connectivity and status of the Connect Home Network

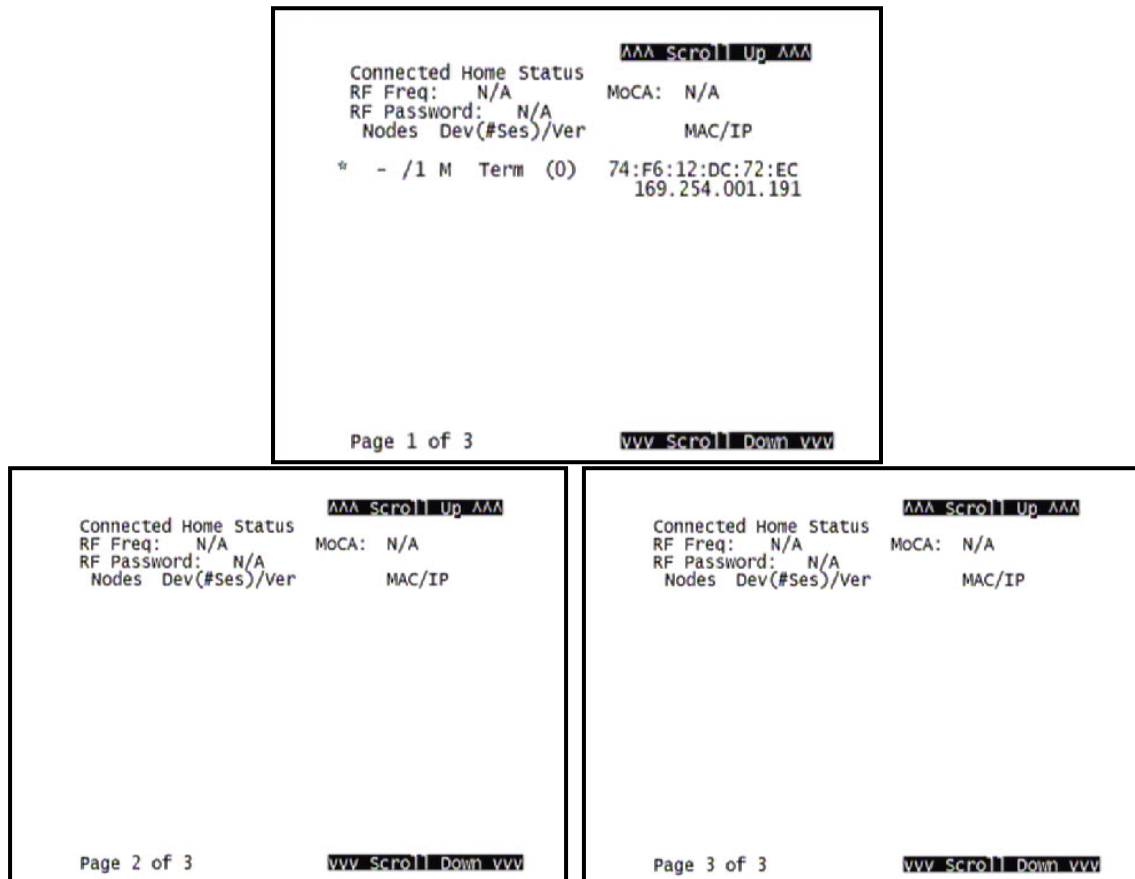

Figure 32: Connected Home Diagnostic Screens

Table 24: Connected Home Diagnostic Field Descriptions

Field	Description
RF Freq	Frequency on which the Connected Home network is communicating.
MoCA	MoCA network status.
RF Password	RF Password is used when the MoCA network has privacy enabled.
Nodes	Node number for each member of network.
Dev(#Ses)/Ver	Number of active content sessions running on each member of network.
MAC/IP	Hardware and Network addresses for each member of the network.
Collecting Data	Displays whether data collecting is taking place on the network.
To Node	Nodes currently sending data over the network.
From Node	Nodes currently receiving data over the network.

6

Troubleshooting

Troubleshooting guidelines follow. If problems still occur after performing the diagnostics, call the TRC for assistance as described in the Introduction.

Problem	Possible Solution
The DCX set-top will not power on	<p>The DCX set-top may have received a software update and may not power on while the new software is being installed. Try again in a few minutes.</p> <ul style="list-style-type: none"> • Verify that the AC power cord is connected to the DCX set-top and an AC outlet. Unplug the DCX set-top from the AC outlet, plug it back in, and then press the POWER button on the remote control. • If the DCX set-top is connected to a switched outlet on another unit, verify that that unit is powered on. Unplug the power cord from the DCX set-top's AC outlet, plug it back in, and then press the POWER button on the remote control. Use an unswitched outlet, if possible.
The remote control does not work	<p>Verify that the remote control is in Cable mode.</p> <p>Verify that there are no obstructions between the remote control and the DCX set-top. Aim the remote control directly at the DCX set-top, not the TV or VCR.</p> <p>The angle between the remote control and the DCX set-top may be too large. Stand in front of the DCX set-top and not too far to either side.</p> <ul style="list-style-type: none"> • Press and release operation keys one at a time, firmly and deliberately. • Check the batteries in the remote control. Install new batteries if needed.
There is no audio when viewing cable channels	<p>Verify that the mute button on the DCX set-top or the remote control has not been pressed. Press mute on the remote control to restore sound.</p> <ul style="list-style-type: none"> • If the DCX set-top audio output is connected to the TV, verify that the mute button on the TV has not been pressed. • If the DCX set-top audio output is connected to a home theater receiver, verify that the receiver is set to the appropriate input source and the mute button on the receiver has not been pressed. • Verify that you have the correct cables for the audio connections. • Verify that the audio cables are firmly connected between the DCX set-top and the audio playback device (TV, receiver, DVD player, etc.).

Problem	Possible Solution
<p>There is no audio from the center and/or surround speakers of a home theater receiver connected to the DCX set-top</p>	<p>Not all programs feature full Dolby® Digital [5.1] or Dolby® Digital Plus [7.1] surround sound. In some cases, the programs may only contain left and right stereo audio.</p> <ul style="list-style-type: none"> • Verify that the S/PDIF cable (coaxial or optical) is firmly connected to the DCX set-top and the home theater receiver. • Verify that the home theater receiver is set to a surround sound audio mode (Dolby Pro Logic®, Dolby Pro Logic II®, Dolby Pro Logic IIx®). • Verify that the receiver is properly configured to work with all connected speakers.
<p>There is no video on the TV screen</p>	<p>Verify that the TV is powered on and set to the appropriate input source for the DCX set-top.</p> <p>Verify that the DCX set-top is powered on and tuned to an authorized cable channel.</p> <p>Verify that all video cables between the DCX set-top and the TV are firmly connected. Verify that the coaxial cable feed is firmly connected to the DCX set-top and the wall jack.</p> <ul style="list-style-type: none"> • If the DCX set-top video output is connected to a home theater unit, verify that the home theater unit is powered on and set to the appropriate input source. • If the DCX set-top video output is connected to a TV through an HDMI™ connection, power off the TV and then power off the DCX set-top. Wait one second and then power on the devices. <p>Not all HDTVs can display every output format (1080i, 720p, 480p, or 480i) available on the DCX set-top. To select a different format:</p> <ol style="list-style-type: none"> 1. Ensure that your DCX set-top is plugged into a power outlet and is turned off. 2. Press the MENU key on the remote control. Your settings are displayed on the DCX set-top OSD. 3. Press the ▲ and ▼ keys to display the HDMI/YPbPr OUTPUT setting. 4. Press the ► key to cycle through the available output formats until a picture displays on the TV.
<p>No closed captions display</p>	<p>Verify on the User Settings menu that closed captions are enabled on the DCX set-top.</p> <p>Verify that closed captions are enabled on the TV.</p> <p><i>Note: Closed captioning may not be available on the current program.</i></p>

Problem	Possible Solution
<p>There are black bars to the right and left of the picture</p>	<p>Widescreen TVs display 4:3 programs in this format unless set to Stretch. Turn on the 4:3 OVERRIDE feature in the User Settings menu. This enables most widescreen TVs to stretch the video to fill the screen (see the TV manual for information about stretching 4:3 video).</p> <ul style="list-style-type: none"> • If the DCX525 is connected to a widescreen TV, verify that the TV TYPE is set to 16:9 in the User Settings menu. <p>Many HD programs are broadcast in pillar-box format with black bars to the left and right of the picture. These programs are broadcast in 16:9 HD formats, even though the video is not 16:9.</p>
<p>There are black bars above and below the picture</p>	<p>All 4:3 HDTVs display HD programs in letterbox format (black bars above and below the picture) because of the shape of the display screen.</p> <ul style="list-style-type: none"> • Turn on the 4:3 OVERRIDE feature in the User Settings menu. This enables most standard-screen TVs to display a full screen picture when the DCX525 is tuned to a 4:3 program. • Set the TV TYPE to 4:3 Pan-Scan. This enables the DCX525 to remove the black bars above and below the picture when possible. <p>Some SD programs are broadcast in the letterbox format with black bars above and below the picture. Some widescreen TVs offer a zoom feature that may be able to remove the black bars (see the TV manual for information about zooming 4:3 video).</p>
<p>There are black bars on all four sides of the picture</p>	<p>This may occur on a 4:3 TV if the 4:3 OVERRIDE setting is OFF. To set 4:3 SD programming to fill the screen, depending on the capabilities of the TV, set 4:3 OVERRIDE to 480i or 480p.</p> <p>This may occur on a 16:9 TV if the active video for an SD broadcast is in letterbox format. To confirm, wait for a commercial or look for a graphic, such as a network logo. If the commercial fills the screen from top to bottom, or the graphic appears below the active video, the program is being letterboxed by the broadcaster. You can minimize this by activating the zoom feature on the TV.</p> <p>A broadcaster may include black bars on either side of a widescreen broadcast. This is called a "hybrid" aspect ratio and results in a black border surrounding the video on a 4:3 TV. Because this is part of the broadcast, the DCX525 cannot correct the video. You may be able to minimize the border using the zoom feature on the TV.</p>



ARRIS Enterprises, Inc.
3871 Lakefield Drive, Suwanee, GA 30024 www.arris.com

365-095-25870 x.2 04/15

